VEHICULAR TECHNOLOGIES: INCREASING CONNECTIVITY

Edited by **Miguel Almeida**

INTECHWEB.ORG

Vehicular Technologies: Increasing Connectivity

Edited by Miguel Almeida

Published by InTech

Janeza Trdine 9, 51000 Rijeka, Croatia

Copyright © 2011 InTech

All chapters are Open Access articles distributed under the Creative Commons Non Commercial Share Alike Attribution 3.0 license, which permits to copy, distribute, transmit, and adapt the work in any medium, so long as the original work is properly cited. After this work has been published by InTech, authors have the right to republish it, in whole or part, in any publication of which they are the author, and to make other personal use of the work. Any republication, referencing or personal use of the work must explicitly identify the original source.

Statements and opinions expressed in the chapters are these of the individual contributors and not necessarily those of the editors or publisher. No responsibility is accepted for the accuracy of information contained in the published articles. The publisher assumes no responsibility for any damage or injury to persons or property arising out of the use of any materials, instructions, methods or ideas contained in the book.

Publishing Process Manager Katarina Lovrecic

Technical Editor Teodora Smiljanic

Cover Designer Martina Sirotic

Image Copyright ssguy, 2010. Used under license from Shutterstock.com

First published March, 2011

Printed in India

A free online edition of this book is available at www.intechopen.com

Additional hard copies can be obtained from orders@intechweb.org

Vehicular Technologies: Increasing Connectivity, Edited by Miguel Almeida

p. cm.

ISBN 978-953-307-223-4

INTECH OPEN ACCESS
PUBLISHER

INTECH open

free online editions of InTech
Books and Journals can be found at
www.intechopen.com

Contents

Preface IX

- Chapter 1 **A Non-Stationary MIMO Vehicle-to-Vehicle Channel Model Derived From the Geometrical T-Junction Model 1**
Ali Chelli and Matthias Pätzold
- Chapter 2 **Simulation of SISO and MIMO Multipath Fading Channels 11**
Antonio Petrolino and Gonçalo Tavares
- Chapter 3 **User Scheduling and Partner Selection for Multiplexing-based Distributed MIMO Uplink Transmission 35**
Ping-Heng Kuo and Pang-An Ting
- Chapter 4 **Resource Allocation for Multi-User OFDMA-Based Wireless Cellular Networks 51**
Dimitri Kténas and Emilio Calvanese Strinati
- Chapter 5 **From Linear Equalization to Lattice-Reduction-Aided Sphere-Detector as an Answer to the MIMO Detection Problematic in Spatial Multiplexing Systems 71**
Sébastien Aubert and Manar Mohaisen
- Chapter 6 **DFT Based Channel Estimation Methods for MIMO-OFDM Systems 97**
Moussa Diallo, Maryline Hélar, Laurent Cariou and Rodrigue Rabineau
- Chapter 7 **Channels and Parameters Acquisition in Cooperative OFDM Systems 115**
D. Neves, C. Ribeiro, A. Silva and A. Gameiro
- Chapter 8 **Fast Power and Channel Adaptation for Mobile Users in OFDMA Multi-Cell Scenarios 137**
L. Reggiani, L. Galati Giordano and L. Dossi

- Chapter 9 **Statistical Properties of the Capacity of Double Nakagami- m Channels for Applications in V2V Dualhop Communication Systems** 153
Gulzaib Rafiq, Bjørn Olav Hogstad and Matthias Pätzoldt
- Chapter 10 **Resource Allocation and User Scheduling in Coordinated Multicell MIMO Systems** 165
Edgar Souza, Robson Vieira, Mari Kobayashi and Mérouane Debbah
- Chapter 11 **Hybrid Evolutionary Algorithm-based Schemes for Subcarrier, Bit, and Power Allocation in Multiuser OFDM Systems** 185
Wei-Cheng Pao, Yung-Fang Chen and Yun-Teng Lu
- Chapter 12 **Reduced-Complexity PAPR Minimization Schemes for MC-CDMA Systems** 205
Mariano García Otero and Luis A. Paredes Hernández
- Chapter 13 **Cognitive Radio Communications for Vehicular Technology – Wavelet Applications** 223
Murrioni Maurizio and Popescu Vlad
- Chapter 14 **Multiple Antenna-Aided Spectrum Sensing Using Energy Detectors for Cognitive Radio** 239
Seung-Hoon Hwang and Jun-Ho Baek
- Chapter 15 **New Method to Generate Balanced 2^n -PSK STTCs** 261
P. Viland, G. Zaharia and J.-F. Hélar
- Chapter 16 **Correlation Coefficients of Received Signal I and Q Components in a Domain with Time and Frequency Axes under Multipath Mobile Channel with LOS and NLOS** 281
Shigeru Kozono, Kenji Ookubo, Takeshi Kozima and Tomohiro Hamashima
- Chapter 17 **Multimodulus Blind Equalization Algorithm Using Oblong QAM Constellations for Fast Carrier Phase Recovery** 299
Jenq-Tay Yuan and Tzu-Chao Lin
- Chapter 18 **Peak-to-Average Power Ratio Reduction for Wavelet Packet Modulation Schemes via Basis Function Design** 315
Ngon Thanh Le, Siva D. Muruganathan and Abu B. Sesay
- Chapter 19 **Outage Performance and Symbol Error Rate Analysis of L-Branch Maximal-Ratio Combiner for κ - μ and η - μ Fading** 333
Mirza Milišić, Mirza Hamza and Mesud Hadžialić

- Chapter 20 **Technological Issues in the Design of Cost-Efficient Electronic Toll Collection Systems 359**
José Santa, Rafael Toledo-Moreo, Benito Úbeda,
Miguel A. Zamora-Izquierdo and Antonio F. Gómez-Skarmeta
- Chapter 21 **Propagation Aspects in Vehicular Networks 375**
Lorenzo Rubio, Juan Reig and Herman Fernández
- Chapter 22 **Propagation Path Loss Modelling in Container Terminal Environment 415**
Slawomir J. Ambroziak, Ryszard J. Katulski,
Jaroslaw Sadowski and Jacek Stefanski
- Chapter 23 **Link Budgets: How Much Energy is Really Received 433**
Aarne Mämmelä, Adrian Kotelba,
Marko Höyhty and Desmond P. Taylor

Cognitive Radio Communications for Vehicular Technology – Wavelet Applications

Murroni Maurizio¹ and Popescu Vlad²

¹*Department of Electrical and Electronic Engineering, University of Cagliari*

²*Department of Electronics and Computers, Transilvania University of Braşov*

¹*Italy*

²*Romania*

1. Introduction

Wireless communications are nowadays a dominant part of our lives: from domotics, through industrial applications and up to infomobility services. The key to the co-existence of wireless systems operating in closely located or even overlapping areas, is sharing of the spectral resource. The optimization of this resource is the main driving force behind the emerging changes in the policies for radio resources allocation. The current approach in spectrum usage specifies fixed frequency bands and transmission power limits for each radio transmitting system. This approach leads to a very low medium utilization factor for some frequency bands, caused by inefficient service allocation over vast geographical areas (radiomobile, radio and TV broadcasting, WiMAX) and also by the usage of large guard bands, obsolete now due to technological progress.

A more flexible use of the spectral resource implies that the radio transceivers have the ability to monitor their radio environment and to adapt at specific transmission conditions. If this concept is supplemented with learning and decision capabilities, we refer to the Cognitive Radio (CR) paradigm. Some of the characteristics of a CR include localization, monitoring of the spectrum usage, frequency changing, transmission power control and, finally, the capacity of dynamically altering all these parameters (Haykin, 2005). This new cognitive approach is expected to have an important impact on the future regulations and spectrum policies.

2. Cognitive radio techniques

The dynamic access at the spectral resource is of extreme interest both for the scientific community as, considering the continuous request for wideband services, for the development of wireless technologies. From this point of view, a fundamental role is played by the Institute of Electrical and Electronic Engineers (IEEE) which in 2007 formed the Standards Coordinating Committee (SCC) 41 on Dynamic Spectrum Access Networks (DySPAN) having as main objective a standard for dynamic access wireless networks. Still within the IEEE frame, the 802.22 initiative defines a new WRAN (Wireless Regional Area Network) interface for wideband access based on cognitive radio techniques in the TV guard bands (the so-called “white spaces”).

Coupled with the advantages and flexibility of CR systems and technologies, there is an ever-growing interest around the world in exploiting CR-enabled communications in vehicular and transportation environments. The integration of CR devices and cognitive radio networks into vehicles and associated infrastructures can lead to intelligent interactions with the transportation system, among vehicles, and even among radios within vehicles. Thus, improvements can be achieved in radio resource management and energy efficiency, road traffic management, network management, vehicular diagnostics, road traffic awareness for applications such as route planning, mobile commerce, and much more.

Still open within the framework of dynamic and distributed access to the radio resource are the methods for monitoring the radio environment (the so-called "spectrum sensing") and the transceiver technology to be used on the radio channels.

A CR system works on an opportunistic basis searching for unused frequency bands called "white spaces" within the radio frequency spectrum with the intent to operate invisibly and without disturbing the primary users (PU) holding a license for one or more frequency bands. Spectrum sensing, that is, the fast and reliable detection of the PU's even in the presence of in-band noise, is still a very complex problem with a decisive impact on the functionalities and capabilities of the CRs.

The spectrum sensing techniques can be classified in two types: local and cooperative (distributed). The local techniques are performed by single devices exploiting the spectrum occupancy information in their spatial neighborhood and can be divided into three categories (Budiarjo et al., 2008): "matched filter" (detection of pilot signals, preambles, etc.), "energy detection" (signal strength analysis) and "feature detection" (classification of signals according to their characteristics). Also, a combination of local techniques in a multi-stage design can be used to improve the sensing accuracy (Maleki et al., 2010). Nevertheless, the above-mentioned techniques are mostly inefficient for signals with reduced power or affected by phenomena typical for vehicular technology applications, such as shadowing and multi-path fading. To overcome such problems, cooperatives techniques can be used. Cooperative sensing is based on the aggregation of the spectrum data detected by multiple nodes using cognitive convergence algorithms in order to avoid the channel impairment problems that can lead to false detections.

2.1 Spectrum sensing techniques

Matched filter

The optimal way for any signal detection is a matched filter, since it maximizes received signal-to-noise ratio. However, a matched filter effectively requires demodulation of a primary user signal. This means that cognitive radio has a priori knowledge of primary user signal at both PHY and MAC layers, e.g. modulation type and order, pulse shaping, packet format. Most of the wireless technologies in operation include the transmission of some sort of pilot sequence, to allow channel estimation, to beacon its presence to other terminals and to give a synchronization reference for subsequent messages. Secondary systems therefore can exploit pilot signals in order to detect the presence of transmissions of primary systems in their vicinity.

For example: TV signals have narrowband pilot for audio and video carriers, CDMA systems have dedicated spreading codes for pilot and synchronization channels OFDM packets have preambles for packet acquisition.

If $X[n]$ is completely known to the receiver then the optimal detector for this case is

$$T(Y) = \sum_{n=0}^{N-1} Y[n]X[n] \underset{H_0}{<} \underset{H_1}{>} \gamma \tag{1}$$

If γ is the detection threshold, then the number of samples required for optimal detection is

$$N = [Q^{-1}(P_D - Q^{-1}(P_{FD}))]^2 (SNR)^{-1} = O(SNR)^{-1}, \tag{2}$$

where PD and PFD are the probabilities of detection and false detection respectively. Hence, the main advantage of matched filter is that due to coherency it requires less time to achieve high processing gain since only $O(SNR)^{-1}$ samples are needed to meet a given probability of detection constraint. However, a significant drawback of a matched filter is that a cognitive radio would need a dedicated receiver for every primary user class.

Energy detector

One approach to simplify matched filtering approach is to perform non-coherent detection through energy detection. This sub-optimal technique has been extensively used in radiometry. An energy detector can be implemented similar to a spectrum analyzer by averaging frequency bins of a Fast Fourier Transform (FFT), as outlined in figure 1. Processing gain is proportional to FFT size N and observation/averaging time T. Increasing N improves frequency resolution which helps narrowband signal detection. Also, longer averaging time reduces the noise power thus improves SNR.

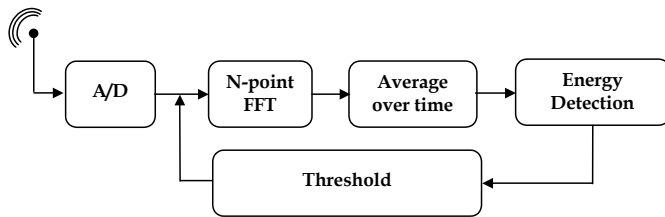

Fig. 1. Block diagram of a matched filter detector

$$T(Y) = \sum_{n=0}^{N-1} Y^2[n] \underset{H_0}{<} \underset{H_1}{>} \gamma \tag{3}$$

$$N = 2[(Q^{-1}(P_{Fd}) - Q^{-1}(P_D))(SNR)^{-1} - Q^{-1}(P_D)] = O(SNR)^{-2} \tag{4}$$

Based on the above formula, due to non-coherent processing $O(SNR)^{-2}$ samples are required to meet a probability of detection constraint. There are several drawbacks of energy detectors that might diminish their simplicity in implementation. First, a threshold used for primary user detection is highly susceptible to unknown or changing noise levels. Even if the threshold would be set adaptively, presence of any in-band interference would confuse the energy detector. Furthermore, in frequency selective fading it is not clear how to set the threshold with respect to channel notches. Second, energy detector does not differentiate

between modulated signals, noise and interference. Since it cannot recognize the interference, it cannot benefit from adaptive signal processing for canceling the interferer. Furthermore, spectrum policy for using the band is constrained only to primary users, so a cognitive user should treat noise and other secondary users differently. Lastly, an energy detector does not work for spread spectrum signals: direct sequence and frequency hopping signals, for which more sophisticated signal processing algorithms need to be devised (Cabric et al., 2004).

Cyclostationary feature detector

Another method for the detection of primary signals is Cyclostationary Feature Detection in which modulated signals are coupled with sine wave carriers, pulse trains, repeated spreading, hopping sequences, or cyclic prefixes. This results in built-in periodicity. These modulated signals are characterized as cyclostationary because their mean and autocorrelation exhibit periodicity. This periodicity is introduced in the signal format at the receiver so as to exploit it for parameter estimation such as carrier phase, timing or direction of arrival. These features are detected by analyzing a spectral correlation function. The main advantage of this function is that it differentiates the noise from the modulated signal energy. This is due to the fact that noise is a wide-sense stationary signal with no correlation however. Modulated signals are cyclostationary due to embedded redundancy of signal periodicity.

Analogous to autocorrelation function spectral correlation function (SCF) can be defined as:

$$S_x^\alpha(f) = \lim_{\tau \rightarrow \infty} \lim_{\Delta t \rightarrow \infty} \frac{1}{\Delta t} \int_{-\Delta t/2}^{\Delta t/2} \frac{1}{\tau} X_\tau(t, f + \alpha / 2) X_\tau^*(t, f - \alpha / 2) dt, \tag{5}$$

with the finite time Fourier transform given by

$$X_\tau(t, v) = \int_{t-\frac{\tau}{2}}^{t+\frac{\tau}{2}} x(u) e^{-j2\pi v u} du. \tag{6}$$

Spectral correlation function is also known as cyclic spectrum. While power spectral density (PSD) is a real valued one-dimensional transform, SCF is a complex valued two-dimensional transform. The parameter α is called the cycle frequency. If $\alpha = 0$ then SCF gives the PSD of the signal.

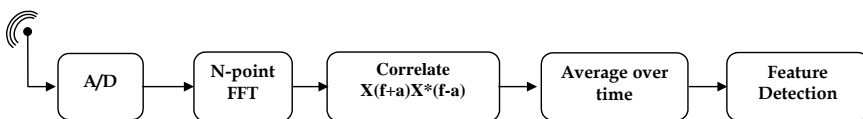

Fig. 2. Block diagram of a cyclostationary feature detector

Because of the inherent spectral redundancy signal selectivity becomes possible. Analysis of signal in this domain retains its phase and frequency information related to timing parameters of modulated signals. Due to this, overlapping features in power spectral

density are non-overlapping features in cyclic spectrum. Hence different types of modulated signals that have identical power spectral density can have different cyclic spectrum.

Implementation of a spectrum correlation function for cyclostationary feature detection is depicted in figure 2. It can be designed as augmentation of the energy detector from figure 1 with a single correlator block. Detected features are number of signals, their modulation types, symbol rates and presence of interferers. Table 1 presents examples of the cyclic frequencies adequate for the most common types of radio signals (Chang, 2006).

The cyclostationary detectors work in two stages. In the first stage the signal $x(k)$, that is transmitted over channel $h(k)$, has to be detected in presence of AWGN $n(k)$. In the second stage, the received cyclic power spectrum is measured at specific cycle frequencies. The signal S_j is declared to be present if a spectral component is detected at corresponding cycle frequencies α_j .

$$S_x^\alpha(f) = \begin{cases} S_n^0(f), & \alpha = 0, \text{signal absent} \\ |H(f)|^2 S_s^0(f) + S_n^0(f), & \alpha = 0, \text{signal present} \\ 0, & \alpha \neq 0, \text{signal absent} \\ H(f + \frac{\alpha}{2})H^*(f - \frac{\alpha}{2})S_s^\alpha(f), & \alpha \neq 0, \text{signal present} \end{cases} \quad (7)$$

The advantages of the cyclostationary feature detection are robustness to noise, better detector performance even in low SNR regions, signal classification ability and operation flexibility because it can be used as an energy detector in $\alpha = 0$ mode. The disadvantage is a more complex processing than energy detection and therefore high speed sensing cannot be achieved. The method cannot be applied for unknown signals because an a priori knowledge of target signal characteristics is needed. Finally, at one time, only one signal can be detected: for multiple signal detection, multiple detectors have to be implemented or slow detection has to be allowed.

Type of Signal	Cyclic Frequencies
Analog Television	Cyclic frequencies at multiples of the TV-signal horizontal line-scan rate
AM signal: $x(t) = a(t)\cos(2\pi f_0 t + \phi_0)$	$\pm 2f_0$
PM and FM signal: $x(t) = \cos(2\pi f_0 t + \phi(t))$	$\pm 2f_0$
Amplitude-Shift Keying: $x(t) = [\sum_{n=-\infty}^{\infty} a_n p(t - nT_0 - t_0)]\cos(2\pi f_0 t + \phi_0)$	$k / T_0 (k \neq 0)$ and $\pm 2f_0 + k / T_0, k = 0, \pm 1, \pm 2, \dots$
Phase-Shift Keying: $x(t) = \cos[2\pi f_0 t + \sum_{n=-\infty}^{\infty} a_n p(t - nT_0 - t_0)]$.	For QPSK, $k / T_0 (k \neq 0)$, and for BPSK $k / T_0 (k \neq 0)$ and $\pm 2f_0 + k / T_0, k = 0, \pm 1, \pm 2, \dots$

Table 1. List of cyclic frequencies for various signal types

Besides cyclostationarity, other features of the received signals can be used for detecting the type of signal. One example is the classification of QPSK, 16QAM and 64QAM constellations based on normalized fourth and sixth-order cumulants (Swami et al., 2000). The cumulants are used as features for discriminating different classes of modulation schemes and are calculated

based on the coefficients of the fast Fourier transform. Cumulants are very robust in the presence of Gaussian Noise (higher order cumulants of Gaussian Noise are equal to zero). When using the Wavelet Transform, the classification of MPSK and MQAM modulations can be done using the normalized histogram of the wavelet coefficients (Prakasam et al., 2008).

Wavelet packets – subband analysis

Within the energy detection method, a particular attention needs to be paid to the properties of the packets wavelet transformation for subband analysis, which, according to the literature, seems to be a feasible alternative to the classical FFT-based energy detection. Vehicular applications are in most cases characterized by the need of coping with fast changes in the radio environment, which lead, in this specific case of cognitive communication, to constrains in terms of short execution time of the spectrum sensing operations. From this point of view, the computational complexity of the wavelet packets method is of the same order of the state-of-the-art FFT algorithms, but the number of mathematical operations is lower using IIR polyphase filters (Murrioni et al., 2010).

To define the wavelet packet basis functions we refer to wavelet multiresolution analysis (WMRA). Let $g_0[n]$ be a unit-energy real causal FIR filter of length which is orthogonal to its even translates; i.e., $\sum_n g_0[n]g_0[n-2m] = \delta[m]$, where $\delta[m]$ is the Kroneker delta, and let g_1 be the (conjugate) quadrature mirror filter (QMF), $g_1[n] = (-1)^n g_0[N-1-n]$. If $g_0[n]$ satisfies some mild technical conditions, we can use an iterative algorithm to find the function $\phi_{0l}(t) = \sqrt{2} \sum_n g_0[n] \phi_{0l}(2t - nT_0)$ for an arbitrary interval T_0 . Subsequently, we can define the family of functions ϕ_{lm} , $l \geq 0$, $1 \leq m \leq 2^l$ in the following (binary) tree-structured manner:

$$\begin{cases} \phi_{l+1,2m-1}(t) = \sum_n g_0[n] \phi_{lm}(t - nT_l) \\ \phi_{l+1,2m}(t) = \sum_n g_1[n] \phi_{lm}(t - nT_l) \end{cases} \quad (8)$$

where $T_l = 2^l T_0$. For any given tree structure, the function at the leafs of the tree form a wavelet packet.

Wavelet packets have a finite duration, $(N-1)T_l$ and are self- and mutually-orthogonal at integer multiples of dyadic intervals. Therefore, they are suitable for subband analysis: a generic signal $x(t)$ can be then decomposed on the wavelet packet basis and represented as a collection of coefficients belonging to orthogonal subbands. Therefore, the total power of $x(t)$ can be evaluated as sum of the contributes of each subband which can be separately computed in the wavelet domain. Let S_k be the k -th subband; if we denote by $\{c_{k,i}\}$ the wavelet coefficients of S_k , the power contribute of S_k is

$$P_k = \frac{2^l}{(N-1)T_l} \sum_i c_{k,i}^2 \quad (9)$$

Figure 3 shows an example of a binary tree decomposition (Fig.3a) and the relevant symbolic subband structure (Fig.3b). It is noticeable how for $l > 1$ (i.e., packet composed by more than 4 leafs) in the frequency Fourier domain the wavelet packets are not ordered as in the corresponding tree.

A drawback to WMRA as described so far is the higher computational complexity compared to classical Fourier subband analysis. Computational burden is reduced by deploying IIR

polyphase filter banks. It is shown that, whereas the computational complexity of the WMRA based on IIR polyphase filters is of the same order of the state-of-the-art FFT algorithms, the number of mathematical operations is lower. Hence, the wavelet subband division and power calculation is a valid candidate for being used as an alternative to the classic FFT-based energy detection. It is therefore suitable for environments where computation time is critical, as the vehicular technology applications are.

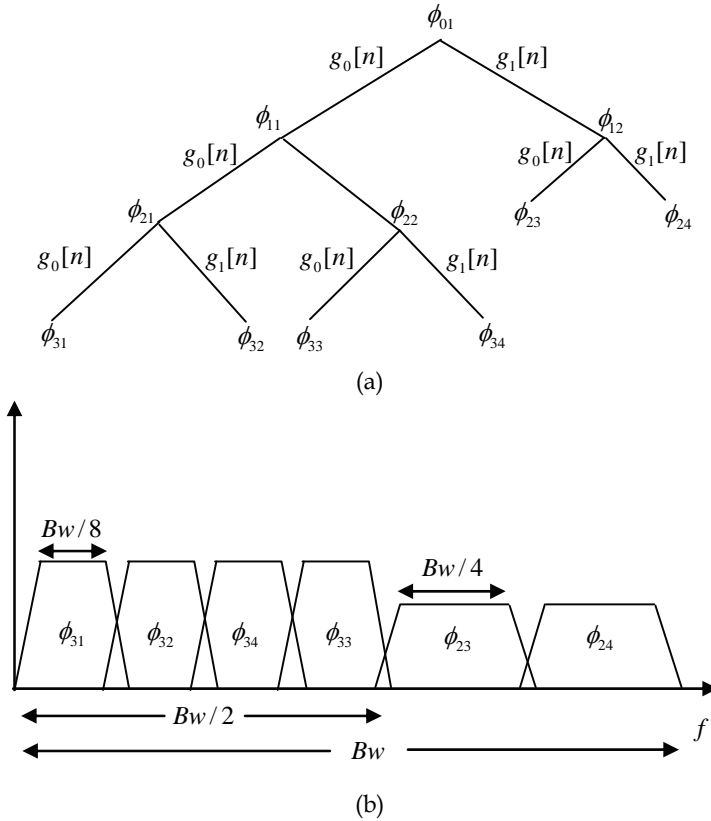

Fig. 3. (a) Wavelet tree structure (b) Corresponding symbolic subband structure

Combined two-stage detection

Since cyclostationary feature detection is somehow complementary to the energy detection, performing better for narrow bands, a combined approach is suggested in (Maleki et al., 2010), using energy detection for wideband sensing and then, for each detected single channel, a feature detection is applied in order to make the final decision whether the channel is occupied or not. First, a coarse energy detection stage is performed over a wider frequency band. Subsequently the presumed free channels are analyzed with the feature detector in order to take the decision.

We investigated in (Murrioni et al., 2010) this combined 2-stage spectrum sensing method for a Wavelet approach, using the wavelet packet transform and the resulting coefficients both

for energy detection as for feature detection. Our research took into consideration a range of frequencies particularly interesting for Vehicular Technologies approaches, the DVB-T channels.

DWPT analysis divides the sensed frequency range into 32 sub-bands in order to contain the all DVB-T channels. The matching process is performed taking into account the known discrepancy between the TV channels order in the Fourier domain and the corresponding sub-bands order in the wavelet domain.

Based on the calculated sub-band power, one or more channels are marked as “white” and can be directly used further by a cognitive transmission system. The list of channels whose signal powers are above a certain threshold is passed to the second stage of the system where a sequential analysis of each of these channels is performed.

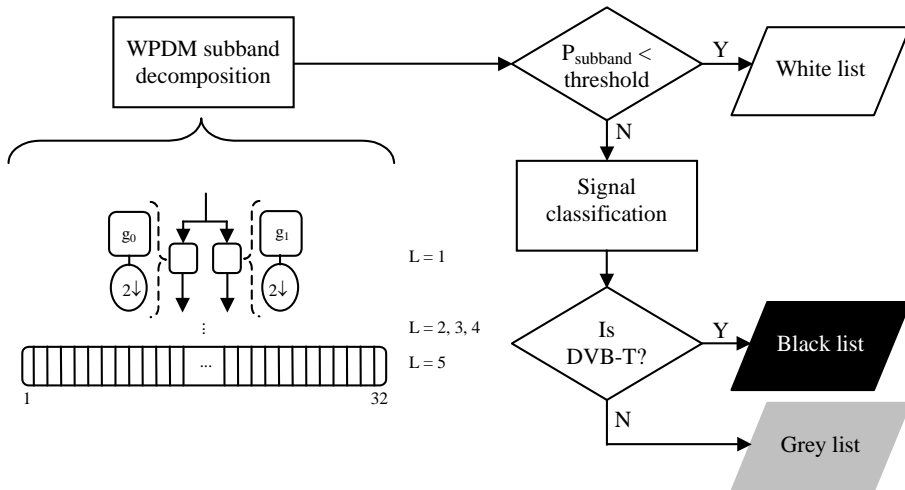

Fig. 4. Flowchart of an application scenario for a two-stage spectrum-sensing scheme in the DVB-T UHF band

The sub-band power computed in the first step is used as a factor to appropriately adjust the values for the thresholds, proportionally with the signal’s intensity. Consequently we can compare the corresponding first and second order moments of the normalized histogram in order to distinguish whether the signal is a PU’s signal, hence a DVB-T signal with a standard modulation, or not (Figure 4).

If the channel is identified as being occupied by a PU, the corresponding channel is definitively marked as “black”, meaning it is undoubtedly used by PUs and therefore not suitable for transmission. If the statistical analysis fails to identify a DVB-T type signal, we can categorize the channel as being “grey”, which in our scenario means that there is no PU transmitting, but still the channel is occupied, most probably by another SU. Therefore, the channel is not completely discarded, being a potential candidate to be analyzed again after a certain amount of time in order to be re-evaluated and eventually included in the white list.

2.2 Cooperative issues

Detection of primary user by the secondary system is critical in a cognitive radio environment. However this is rendered difficult due to the challenges in accurate and

reliable sensing of the wireless environment. Secondary users might experience losses in the signal which can result in an incorrect judgment of the wireless environment, which can in turn cause interference at the licensed primary user by the secondary transmission. Furthermore, the issues with signal quality are aggravated when secondary users rapidly change location, as it is the case for specific vehicular technology applications. Briefly, as shown in figure 5, unreliable results can be produced based on the following phenomena:

- Multipath: a sensor CR1 under multipath receiving conditions features short term Rayleigh fading. The fluctuations of the power level may cause unreliable detection.
- Shadowing: a sensor CR2 may move behind an obstacle, exhibiting lognormal long term fading. Its covered position may create disturbance for a PRx in its proximity (hidden terminal problem).
- Distance-dependent path loss: a sensor CR3 lies outside the primary transmission range. It receives a low power level due to the distance, but its transmission can produce interference to the primary receiver, which is inside the primary range.

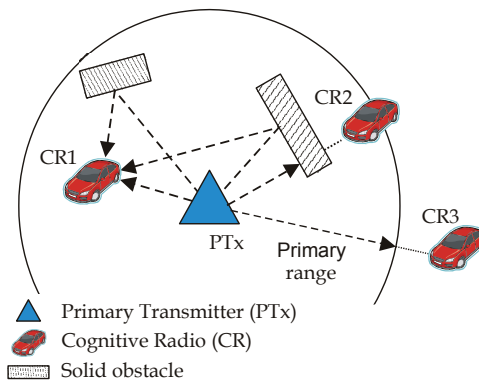

Fig. 5. Layout of a network with moving terminals

This arises the necessity for the cognitive radio to be highly robust to channel impairments and also to be able to detect extremely low power signals. These stringent requirements pose a lot of challenges for the deployment of CR networks.

Channel impairments and low power detection problems in CR can be alleviated if multiple CR users cooperate in sensing the channel. (Thanayankizil & Kailas, 2008) suggest different cooperative topologies that can be broadly classified into three regimes according to their level of cooperation:

Decentralized Uncoordinated Techniques: the cognitive users in the network don't have any kind of cooperation which means that each CR user will independently detect the channel, and if a CR user detects the primary user it would vacate the channel without informing the other users. Uncoordinated techniques are fallible in comparison with coordinated techniques. Therefore, CR users that experience bad channel realizations (shadowed regions) detect the channel incorrectly thereby causing interference at the primary receiver.

Centralized Coordinated Techniques: in these kinds of networks, an infrastructure deployment is assumed for the CR users. CR user that detects the presence of a primary transmitter or receiver informs a CR controller. The CR controller can be a wired immobile device or another CR user. The CR controller notifies all the CR users in its range by means

of a broadcast control message. Centralized schemes can be further classified according to their level of cooperation into

- Partially Cooperative: in partially cooperative networks nodes cooperate only in sensing the channel. CR users independently detect the channel inform the CR controller which then notifies all the CR users. One such partially cooperative scheme was considered by (Liu & Shankar, 2006) where a centralized Access Point (CR controller) collected the sensory information from the CR users in its range and allocated spectrum accordingly;
- Totally Cooperative Schemes: in totally cooperative networks nodes cooperate in relaying each other's information in addition to cooperatively sensing the channel. For example, two cognitive users D1 and D2 are assumed to be transmitting to a common receiver and in the first half of the time slot assigned to D1, D1 transmits and in the second half D2 relays D1's transmission. Similarly, in the first half of the second time slot assigned to D2, D2 transmits its information and in the second half D1 relays it.

Decentralized Coordinated Techniques: various algorithms have been proposed for the decentralized techniques, among which the gossiping algorithms, which do cooperative sensing with a significantly lower overhead. Other decentralized techniques rely on clustering schemes where cognitive users form in to clusters and these clusters coordinate amongst themselves, similar to other already known sensor network architecture (i.e. ZigBee).

All these techniques for cooperative spectrum sensing raise the need for a control channel that can be either implemented as a dedicated frequency channel or as an underlay UWB channel. Wideband RF front-end tuners/filters can be shared between the UWB control channel and normal cognitive radio reception/transmission. Furthermore, with multiple cognitive radio groups active simultaneously, the control channel bandwidth needs to be shared. With a dedicated frequency band, a CSMA scheme may be desirable. For a spread spectrum UWB control channel, different spreading sequencing could be allocated to different groups of users.

2.3 Transmission techniques

In a CR environment, terminals are assumed to be able to detect any unoccupied frequencies and to estimate the strength of the received signal of nearby primary users by spectrum sensing, as presented in the previous section. Once a CR user detects free frequency spectrum within the licensed frequency range, he may negotiate with the primary system, or begin data transmission without extra permission, depending on the CR system structure. If any primary users become active in the same frequency band later on, the CR user has to clear this band as soon as possible, giving priority to the primary users. Also, CR users should quit their communication if the estimated SNR levels of the primary users are below an acceptable level. When a CR user operates in a channel adjacent to any active primary users' spectrums, ACI (adjacent channel interference) occurs between the two parties. However, the performance of the primary system should be maintained, whether spectrum sharing is allowed or not. We assume that a minimum SNR requirement is predefined for the primary system so that the maximum allowable ACI at each location can be evaluated by the CR user. The CR user can then determine whether he may use the frequency band or not. At the same time, the CR user needs to avoid the influence of interference from primary users in order to maximize its own data throughput.

Other properties of his type of radio are the ability to operate at variable symbol rates, modulation formats (e.g. low to high order QAM), different channel coding schemes, power

levels and the use of multiple antennas for interference nulling, capacity increase or range extension (beam forming).

The most likely basic strategy will be based on multicarrier OFDM-like modulation across the entire bandwidth in order to most easily resolve the frequency dimension with subsequent spatial and temporal processing.

OFDM Modulation

OFDM has become the modulation of choice in many broadband systems due to its inherent multiple access mechanism and simplicity in channel equalization, plus benefits of frequency diversity and coding. The transmitted OFDM waveform is generated by applying an inverse fast Fourier transform (IFFT) on a vector of data, where number of points N determines the number of sub-carriers for independent channel use, and minimum resolution channel bandwidth is determined by W/N , where W is the entire frequency band accessible by any cognitive user.

The frequency domain characteristics of the transmitted signal are determined by the assignment of non-zero data to IFFT inputs corresponding to sub-carriers to be used by a particular cognitive user. Similarly, the assignment of zeros corresponds to channels not permitted to use due to primary user presence or channels used by other cognitive users. The output of the IFFT processor contains N samples that are passed through a digital-to-analog converter producing the wideband waveform of bandwidth W . A great advantage of this approach is that the entire wideband signal generation is performed in the digital domain, instead of multiple filters and synthesizers required for the signal processing in analog domain.

From the cognitive network perspective, OFDM spectrum access is scalable while keeping users orthogonal and non-interfering, provided the synchronized channel access. However, this conventional OFDM scheme does not provide truly band-limited signals due to spectral leakage caused by sinc-pulse shaped transmission resulted from the IFFT operation. The slow decay of the sinc-pulse waveform, with first side lobe attenuated by only 13.6dB, produces interference to the adjacent band primary users which is proportional to the power allocated to the cognitive user on the corresponding adjacent sub-carrier. Therefore, a conventional OFDM access scheme is not an acceptable candidate for wideband cognitive radio transmission.

To overcome these constraints (Rajbanshi et. al., 2006) suggest non-contiguous OFDM (NC-OFDM) as an alternative, a schematic of an NC-OFDM transceiver being shown in figure 6. The transceiver splits a high data rate input, $x(n)$, into N lower data rate streams. Unlike conventional OFDM, not all the sub carriers are active in order to avoid transmission unoccupied frequency bands. The remaining active sub carriers can either be modulated using M-ary phase shift keying (MPSK), as shown in the figure, or M-ary quadrature amplitude modulation (MQAM). The inverse fast Fourier transform (IFFT) is then used to transform these modulated sub carrier signals into the time domain. Prior to transmission, a guard interval, with a length greater than the channel delay spread, is added to each OFDM symbol using the cyclic prefix (CP) block in order to mitigate the effects of inter-symbol interference (ISI). Following the parallel-to-serial (P/S) conversion, the base band NC-OFDM signal, $s(n)$, is then passed through the transmitter radiofrequency (RF) chain, which amplifies the signal and upconverts it to the desired centre frequency. The receiver performs the reverse operation of the transmitter, mixing the RF signal to base band for processing, yielding the signal $r(n)$. Then the signal is converted into parallel streams, the cyclic prefix is discarded, and the fast Fourier transform (FFT) is applied to transform the time domain data

into the frequency domain. After the distortion from the channel has been compensated via per sub carrier equalization, the data on the sub carriers is demodulated and multiplexed into a reconstructed version of the original high-speed input.

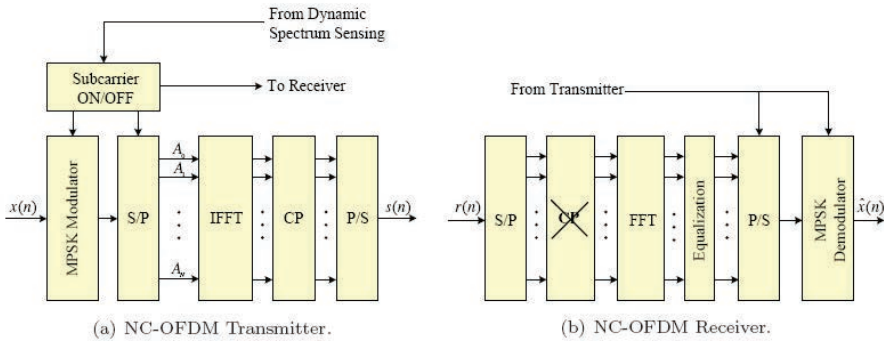

Fig. 6. Schematic of an NC - OFDM transceiver

NC-OFDM was evaluated and compared, both qualitatively and quantitatively with other candidate transmission technologies, such as MC-CDMA and the classic OFDM scheme. The results show that NC-OFDM is sufficiently agile to avoid spectrum occupied by incumbent user transmissions, while not sacrificing its error robustness.

Wavelet packet transmission method

In the last 10 years another multicarrier transmission technique has emerged as a valid alternative to OFDM and its modified versions.

The theoretical background relies on the synthesis of the discrete wavelet packet transform that constructs a signal as the sum of $M = 2^J$ waveforms. Those waveforms can be built by J successive iterations each consisting of filtering and upsampling operations. Noting $\langle \cdot, \cdot \rangle$ the convolution operation, the algorithm can be written as:

$$\begin{cases} \varphi_{j,2m}[k] = \langle h_{lo}^{rec}[k], \varphi_{j-1,m}[k/2] \rangle \\ \varphi_{j,2m}[k] = \langle h_{hi}^{rec}[k], \varphi_{j-1,m}[k/2] \rangle' \end{cases} \tag{10}$$

with

$$\varphi_{j,2m}[k] = \begin{cases} 1, & \text{for } k = 1 \\ 0, & \text{otherwise} \end{cases} \forall m, \tag{11}$$

where j is the iteration index, $1 \leq j \leq J$ and m the waveform index $0 \leq m \leq M - 1$.

Using usual notation in discrete signal processing, $\varphi_{j,m}[k/2]$ denotes the upsampled-by-two version of $\varphi_{j,m}[k]$. For the decomposition, the reverse operations are performed, leading to the complementary set of elementary blocks constituting the wavelet packet transform depicted in Figure 7. In orthogonal wavelet systems, the scaling filter h_{lo}^{rec} and dilatation filter h_{hi}^{rec} form a quadrature mirror filter pair. Hence knowledge of the scaling filter and

wavelet tree depth is sufficient to design the wavelet transform. It is also interesting to notice that for orthogonal WPT, the inverse transform (analysis) makes use of waveforms that are time-reversed versions of the forward ones. In communication theory, this is equivalent to using a matched filter to detect the original transmitted waveform.

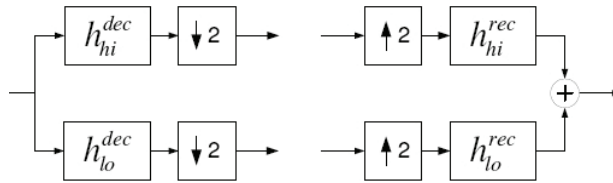

Fig. 7. Wavelet packet elementary block decomposition and reconstruction

A particularity of the waveforms constructed through the WPT is that they are longer than the transform size. Hence, WPM belongs to the family of overlapped transforms, the beginning of a new symbol being transmitted before the previous one(s) ends. The waveforms being M -shift orthogonal, the inter-symbol orthogonality is maintained despite this overlap of consecutive symbols. This allows taking advantage of increased frequency domain localization provided by longer waveforms while avoiding system capacity loss that normally results from time domain spreading. The waveforms length can be derived from a detailed analysis of the tree algorithm. Explicitly, the wavelet filter of length L_0 generates M waveforms of length

The construction of a wavelet packet basis is entirely defined by the wavelet-scaling filter, hence its selection is critical. This filter solely determines the specific characteristics of the transform. In multicarrier systems, the primary characteristic of the waveform composing the multiplex signal is out-of-band energy. Though in an AWGN channel this level of out-of-band energy has no effect on the system performance thanks to the orthogonality condition, this is the most important source of interference when propagation through the channel causes the orthogonality of the transmitted signal to be lost. A waveform with higher frequency domain localization can be obtained with longer time support. On the other hand, it is interesting to use waveforms of short duration to ensure that the symbol duration is far shorter than the channel coherence time. Similarly, short waveforms require less memory, limit the modulation-demodulation delay and require less computation. Those two requirements, corresponding to good localization both in time and frequency domain, cannot be chosen independently. In fact, it has been shown that in the case of wavelets, the bandwidth-duration product is constant. This is usually referred to as the uncertainty principle.

Finally, a minor difference between OFDM and WPM remains to be emphasized. In the former, the set of waveforms is by nature defined in the complex domain. WPM, on the other hand, is generally defined in the *real* domain but can be also defined in the *complex* domain, solely depending of the scaling and dilatation filter coefficients. Since the most commonly encountered WPT are defined in the real domain, it has naturally led the authors to use PAM. It is nevertheless possible to translate the M real waveform directly in the complex domain. The resulting complex WPT is then composed of $2M$ waveforms forming an orthogonal set.

In WPDM binary messages $x_m[n]$ have polar representation (i.e., $x_m[n] = \pm 1$), waveform coded by pulse amplitude modulation (PAM) of $\phi_m(t - nT_1)$ and then added together to

form the composite signal $s(t)$. WPDM can be implemented using a transmultiplexer and a single modulator. For a two level decomposition

$$s(t) = \sum_k x_{01}[k] \phi_{01}(t - kT_0), \tag{12}$$

where $x_{01}[k] = \sum_{(l,m) \in \Gamma} \sum_n f_{lm}[k - 2^l n]$, with Γ being the set of terminal index pairs and $f_{lm}[k]$ the equivalent sequence filter from the (l,m) -th terminal to the root of the tree, which can be found recursively from (8). The original message can be recovered from $x_{01}[k]$ using

$$x_{lm}[n] = \sum_k f_{lm}[k - 2^l n] x_{01}[k]. \tag{13}$$

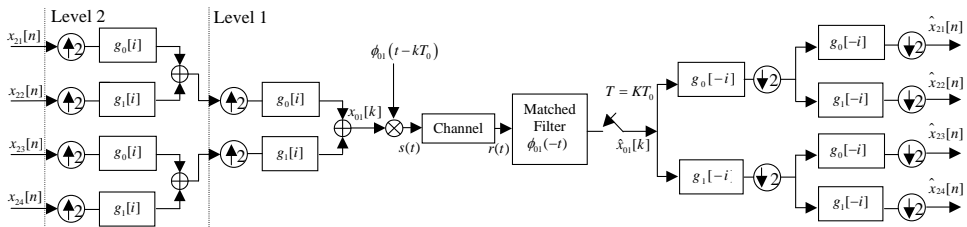

Fig. 8. Transmitter and receiver for a two-level WPDM system

Adaptive modulation

Adaptive modulation is only appropriate for duplex communication between two or more stations because the transmission parameters have to be adapted using some form of a two-way transmission in order to allow channel measurements and signaling to take place. Transmission parameter adaptation is a response of the transmitter to the time-varying channel conditions. In order to efficiently react to the changes in channel quality, the following steps need to be taken:

- Channel quality estimation: to appropriately select the transmission parameters to be employed for the next transmission, a reliable estimation of the channel transfer function during the next active transmission slot is necessary. This is done at the receiver and the information about the channel quality is sent to the transmitter for next transmission through a feedback channel.
- Choice of the appropriate parameters for the next transmission: based on the prediction of the channel conditions for the next time slot, the transmitter has to select the appropriate modulation modes for the sub-carriers.
- Signaling or blind detection of the employed parameters: the receiver has to be informed, as to which demodulator parameters to employ for the received packet.

In a scenario where channel conditions fluctuate dynamically, systems based on fixed modulation schemes do not perform well, as they cannot take into account the difference in channel conditions. In such a situation, a system that adapts to the worst-case scenario would have to be built to offer an acceptable bit-error rate. To achieve a robust and a spectrally efficient communication over multi-path fading channels, adaptive modulation is used, which adapts the transmission scheme to the current channel characteristics. Taking advantage of the time-varying nature of the wireless channels, adaptive modulation based

systems alter transmission parameters like power, data rate, coding, and modulation schemes, or any combination of these in accordance with the state of the channel. If the channel can be estimated properly, the transmitter can be easily made to adapt to the current channel conditions by altering the modulation schemes while maintaining a constant BER. This can be typically done by estimating the channel at the receiver and transmitting this estimate back to the transmitter. Thus, with adaptive modulation, high spectral efficiency can be attained at a given BER in good channel conditions, while a reduction in the throughput is experienced in degrading channel conditions. The basic block diagram of an adaptive modulation based cognitive radio system is shown in figure 9. The block diagram provides a detail view of the whole adaptive modulation system with all the necessary feedback paths.

It is assumed that the transmitter has a perfect knowledge of the channel and the channel estimator at the receiver is error-free and there is no time delay. The receiver uses coherent detection methods to detect signal envelopes. The adaptive modulation, M-ary PSK, M-QAM, and M-ary AM schemes with different modes are provided at the transmitter. With the assumption that the estimation of the channel is perfect, for each transmission, the mode is adjusted to maximize the data throughput under average BER constraint, based on the instantaneous channel SNR. Based on the perfect knowledge about the channel state information (CSI), at all instants of time, the modes are adjusted to maximize the data throughput under average BER constraint.

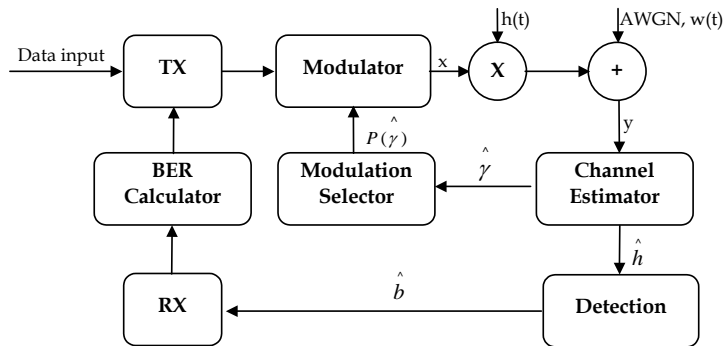

Fig. 9. Basic block diagram of an adaptive modulation - based cognitive radio system

The data stream, $b(t)$ is modulated using a modulation scheme given by $P_k(\hat{\gamma})$, the probability of selecting k^{th} modulation mode from K possible modulation schemes available at the transmitter, which is a function of the estimated SNR of the channel. Here, $h(t)$ is the fading channel and $w(t)$ is the AWGN channel. At the receiver, the signal can be modeled as:

$$y(t) = h(t) x(t) + w(t) \quad (14)$$

where $y(t)$ is the received signal, $h(t)$ is the fading channel impulse response, and $w(t)$ is the Additive White Gaussian Noise (AWGN). The estimated current channel information is returned to the transmitter to decide the next modulation scheme. The channel state information $\hat{h}(t)$ is also sent to the detection unit to get the detected stream of data, $\hat{b}(t)$.

3. Conclusion

Our research investigates the use of the Wavelet transform and the Wavelet Packets for cognitive radio purposes. We are applying the wavelet approach both for spectrum sensing, as for adaptive multicarrier transmission, for offering a complete, wavelet-based solution for cognitive application applied on the problematic of vehicular communication (channel impairments, high relative velocity of the communication peers).

4. References

- Haykin, S. (2005). Cognitive radio: Brain-empowered wireless communications, *IEEE Journal on Selected Areas in Communications*, vol. 25, pp. 201–22, February 2005.
- Budiarjo, I., Lakshmanan, M. K. & H. Nikookar (2008). Cognitive Radio Dynamic Access Techniques. In *Wireless Personal Communications*, Volume 45, Number 3 / May, 2008, Springer Netherlands
- Maleki, S., Pandharipande, A. & Leus, G. (2010). Two-Stage Spectrum Sensing for Cognitive Radios. *Proceedings of the ICASSP 2010 Conference*, March 2010, Dallas, USA.
- Murroni, M. & Popescu, V. (2010). Cognitive Radio HDTV Multi-Vision System in the 700 MHz UHF TV Band, *IEEE International Symposium on Broadband Multimedia Systems and Broadcasting 2010*, Shanghai, 2010
- TWWong, K. M., Wu, J., Davidson, T. N. & Jin, Q. (1997). Wavelet packet division multiplexing and wavelet packet design under timing error effects, *IEEE Trans. Signal Processing*, vol. 45, no. 12, pp- 2877-2890, December 1997.
- Cabric, D., Mishra, S.M. & Brodersen, R.W. (2004). Implementation issues in spectrum sensing for cognitive radios. *Signals, Systems and Computers, 2004. Conference Record of the Thirty-Eighth Asilomar Conference*, vol.1, no., pp. 772- 776 Vol.1, 7-10 Nov. 2004
- Chang, S (2006). Analysis of Proposed Sensing Schemes: *IEEE 802.22-06/0032r0*. February 2006
- Thanayankizil, L. & Kailas, A. (2008). Spectrum Sensing Techniques (II): Receiver Detection and Interference Management
- Liu, X. & Shankar, S. (2006). Sensing-based opportunistic channel access, *ACM Journal on Mobile Networks and Applications (MONET)*, Vol. 11, No. 1, Feb. 2006, p. 577-591, 2006.
- Rajbanshi R., Chen Q., Wyglinski A. M., Evans J.B. & Minden G. J (2006). Comparative Study of Frequency Agile Data Transmission Schemes for Cognitive RadioTransceivers, *ACM International Conference Proceeding Series; Vol. 222, Proceedings of the first international workshop on Technology and policy for accessing spectrum* Boston, 2006
- Maleki, S., Pandharipande A. & Leus, G. (2010). Two-Stage Spectrum Sensing for Cognitive Radios. *Proceedings of the ICASSP 2010 Conference*, March 2010, Dallas, USA.
- Swami, A. & Sadler, B.M., (2000). Hierarchical digital modulation classification using cumulants. *IEEE Trans. Communications*, vol. 48, pp. 416-429, March 2000.
- Prakasam, P. & Madheswaran, M. (2008). M-ary Shift Keying Modulation Scheme Identification Algorithm Using Wavelet Transform and Higher Order Statistical Moments. *Journal of Applied Science* 8(1), pages 112-119, 2008.
- Murroni, M., Fadda, M. & Popescu, V. (2010). Spectrum Sensing in the DVB-T Bands using Combined Energy Detection and Signal Classification in the Wavelet Domain. *Wireless Personal Multimedia Communications Symposium 2010 (WPMC 2010)*; Recife, Brazil.