

PAPER • OPEN ACCESS

A comparative analysis between some dynamic models for the vehicle suspension system

To cite this article: C Alexandru 2020 *IOP Conf. Ser.: Mater. Sci. Eng.* **997** 012069

View the [article online](#) for updates and enhancements.

You may also like

- [Ride performance of a high speed rail vehicle using controlled semi active suspension system](#)
Sunil Kumar Sharma and Anil Kumar
- [Determination and Characterization of Optimum Non-Linear Damping in Vehicle Suspension System](#)
Ming Foong Soong, Kah Yin Goh and Swee King Phang
- [Design and vibration control of military vehicle suspension system using magnetorheological damper and disc spring](#)
Sung Hoon Ha, Min-Sang Seong and Seung-Bok Choi



UNITED THROUGH SCIENCE & TECHNOLOGY

 **The Electrochemical Society**
Advancing solid state & electrochemical science & technology

**248th
ECS Meeting**
Chicago, IL
October 12-16, 2025
Hilton Chicago

**Science +
Technology +
YOU!**

**Register by
September 22
to save \$\$**

REGISTER NOW

The advertisement features a central image of a smiling woman with long dark hair, wearing a brown blazer, standing against a blue background with a network of white dots and lines. The background is framed by decorative borders at the top and bottom consisting of a repeating pattern of blue and white circular motifs.

A comparative analysis between some dynamic models for the vehicle suspension system

C Alexandru¹

¹Transilvania University of Brasov, Romania

E-mail: calex@unitbv.ro

Abstract. This article deals a comparative analysis between several representative dynamic models for the suspension system of the motor vehicles, namely quarter-vehicle, half-vehicle and full-vehicle models. The dynamic model of the suspension system contains the guiding linkages of the front and rear wheels/axle, by case, along with the elastic and dissipative suspension elements (helical springs, shock absorbers/dampers, buffers limiting the expansion & compression suspension travel, bushings, tires). The dynamic analysis (simulation) of the considered models was carried out with the help of virtual prototyping software solution ADAMS (currently developed by MSC Software Corporation), by considering the dynamic with shock regime, which consists in the sudden release of the car to fall on the ground from a given height. This is one of the standard tests in automotive industry for evaluating the comfort performance of the vehicles.

1. Introduction

The wheel/axle guiding & suspension system of the motor vehicles consists from a set of bodies (theoretically rigid), which are interconnected by geometrical constraints (joints), elastic and dissipative elements (such as springs, shock absorbers, buffers limiting the suspension vertical travel, anti-roll bars, bushings, and tires), being subjected to a complex group of external (action) and internal (reaction) forces.

Unlike the kinematic and static models, in which the car body is considered to be rigidly attached to ground (so, fixed) [1-3], for the dynamic study the car body (as sprung mass) is a movable part, having in the general case six degrees of freedom (DOF), corresponding to the three linear displacements (longitudinal, transversal and vertical) and the three angular oscillations (roll, pitch and yaw). Taking into account the constructive features of the current vehicle guiding & suspension systems, some of the above specified displacements - oscillations are much smaller compared to the others, so the dynamic models can be constituted/defined by considering only the main movements of the vehicle (car body).

In these terms, the work deals with a comparative analysis between several representative dynamic models of the vehicle suspension systems, in a gradual approach (on levels of complexity), from the simplest model (i.e. the linear one) to the most complex model (i.e. the full-vehicle model), also considering some intermediate (partial) models, namely half-vehicle and quarter-vehicle. The dynamic analysis of the considered models was carried out with the help of virtual prototyping environment ADAMS. The benefits of using such CAE (Computer Aided Engineering) software solutions in the design process of the mechanical & mechatronic systems are reflected (pointed out) in various types of applications, such as those presented in [4-8].



2. Dynamic regimes and models

The external loading of the suspension mechanism depends on the vehicle running regime/mode. The following regimes are frequently used (simulated) for testing the dynamic behaviour of the vehicle suspension systems (Figure 1):

(a) passing over bumps (obstacles), usually by simulating the laboratory bench test, in which the vehicle wheels are anchored on linear actuators that generate the vertical displacements of the wheels, thus simulating the road bump profiles;

(b) dynamic regime with shock, by raising the vehicle to a certain height (denoted "h" in Figure 1, b) followed by its release (the free fall of the vehicle is thus simulated);

(c) skidding (sliding) regime, usually by applying a lateral force to the centre of mass of vehicle, which materializes the centrifugal force that appears at a steering manoeuvre.

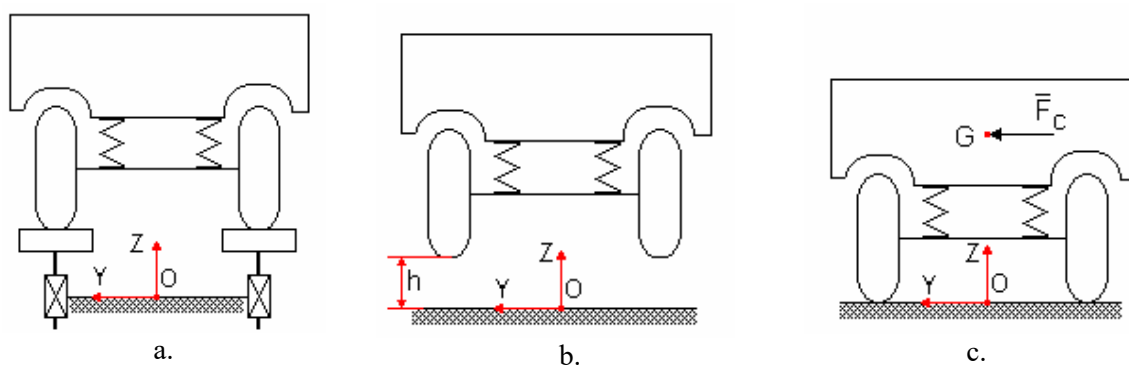

Figure 1. Dynamic regimes for evaluating the suspension system behaviour.

In literature, some of the most commonly addressed models are the linear ones, characterized by linear elastic characteristics and by disregarding the wheel and/or axle guiding linkages. For example, Figure 2 shows the linear dynamic model for a vehicle with independent suspension of the front wheels and dependent suspension of the rear wheels (connected on the rear beam axle), which includes, in addition to the sprung mass, three unsprung masses (left front wheel carrier, right front wheel carrier, and rear axle). This linear model has 7 degrees of freedom, of which 3 are corresponding to the sprung mass (i.e. the car body), namely the vertical, roll and pitch oscillations, while the other 4 degrees of freedom are used to describe the movements of front & rear unsprung parts.

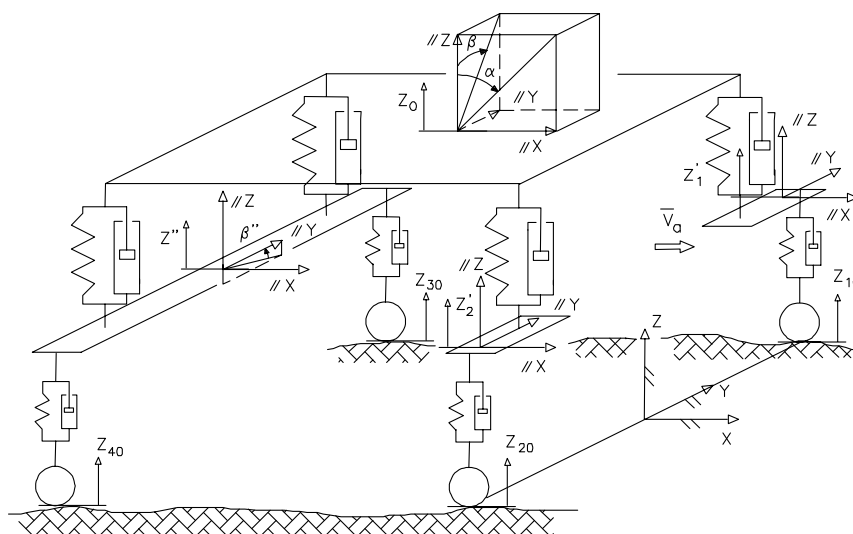

Figure 2. A linear model for the vehicle suspension system.

The set of independent generalized coordinates specific to the linear models differs depending on the type of suspension used for the two axles. For example, there are the following independent generalized coordinates for the linear model shown in Figure 2: $q_1 = Z_0$, $q_2 = Z_1'$, $q_3 = Z_2'$, $q_4 = Z''$, $q_5 = \alpha$, $q_6 = \beta$, $q_7 = \beta''$, where: Z_0 - the vertical displacement of the car body; $Z_{1,2}'$ - the vertical displacements of the front unsprung masses; Z'' - the vertical displacement of the rear unsprung mass; α - the pitch oscillation of the sprung mass; β - the roll oscillation of the sprung mass; β'' - the roll oscillation of the rear unsprung mass. In Figure 2, X-axis is arranged longitudinally, Y-axis transversally, and Z-axis vertically.

More accurate dynamic models for the vehicle suspension systems are obtained by taking into consideration the wheel and/or axle guiding linkages, and the non-linear phenomena that occur in the suspension system, including in the terms of elastic (force vs. deflection) and dissipative (force vs. velocity) characteristics.

It is obvious that for the accurate assessment of the dynamic behavior of the vehicle it is necessary to consider the vehicle as a whole, including both front and rear guiding & suspension subsystems, due to the reciprocal influences induced by the car body oscillations. This integrated approach creates the conditions to accurately evaluate the dynamic behavior of the vehicle.

Due to the high complexity of the full-vehicle model, in order to minimize the errors in the case of a global approach (for the whole suspension system), it could be useful to firstly study some partial (segmented) models, which aim only the suspension mechanism for a single wheel (so called quarter-car model) or axle (half-car model), as these are schematically represented in Figure 3. The scheme shown in Figure 3,a corresponds to a half-car model (for a wheel suspension), while the schemes in Figure 3,b-d are corresponding to half-car models, as follows: left and right front or rear wheels (b), front wheel - rear wheel (c), and rear axle (d), respectively.

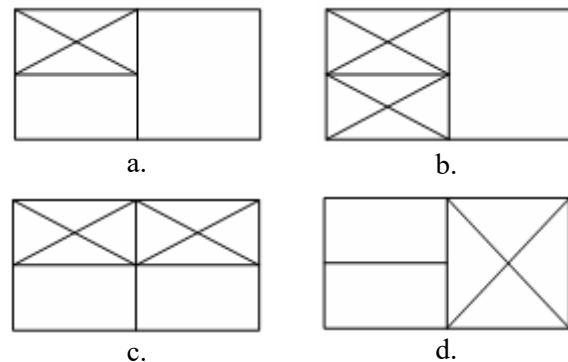

Figure 3. Schematics of the partial models.

In the case of the partial (quarter and half) vehicle models, in the absence of one or more wheels, the equilibrium/support of the car body is achieved through the use of a fictitious joint (connection) to the ground. Even if such models generate certain deviations regarding the car body behavior (by neglecting or affecting some oscillations), by properly choosing the connection between car body and ground there can be obtained results quite close to reality (i.e. the full-car model).

In these circumstances, the quarter-car model is frequently used for evaluating the vertical movement (as vertical oscillations amplitude and frequency) of the vehicle/car body. Therefore, the fictitious connection of the car body is modelled by a translational joint to the fixed part (i.e. the ground), along to the vertical axis that belongs to the median plane (Figure 4, a).

The half-car models can be used both for evaluating the vertical movement and the roll oscillations at the front/rear axle level (according to the schemes shown in Figure 3,b, d), and respectively the pitch oscillations (according to Figure 3,c). Depending on the intended purpose, the connection of the car body to ground can be assured by a planar joint in the vertical-transversal plane of the considered axle (front or rear) - for evaluating the roll oscillations (Figure 4,b), or a planar joint in the vertical-longitudinal plane - for evaluating the pitch oscillations (Figure 4,c), or respectively a spherical joint in the medial longitudinal plane of the vehicle - for evaluating all the relevant oscillations of the car body (Figure 4, d).

The half-car model with transversal planar joint takes into account only the part of the car body that corresponds to the load on the considered axle (front or rear), according to the mass distribution on the two axles of the vehicle. The planar joint is actually equivalent to a third car body support point located at " ∞ ".

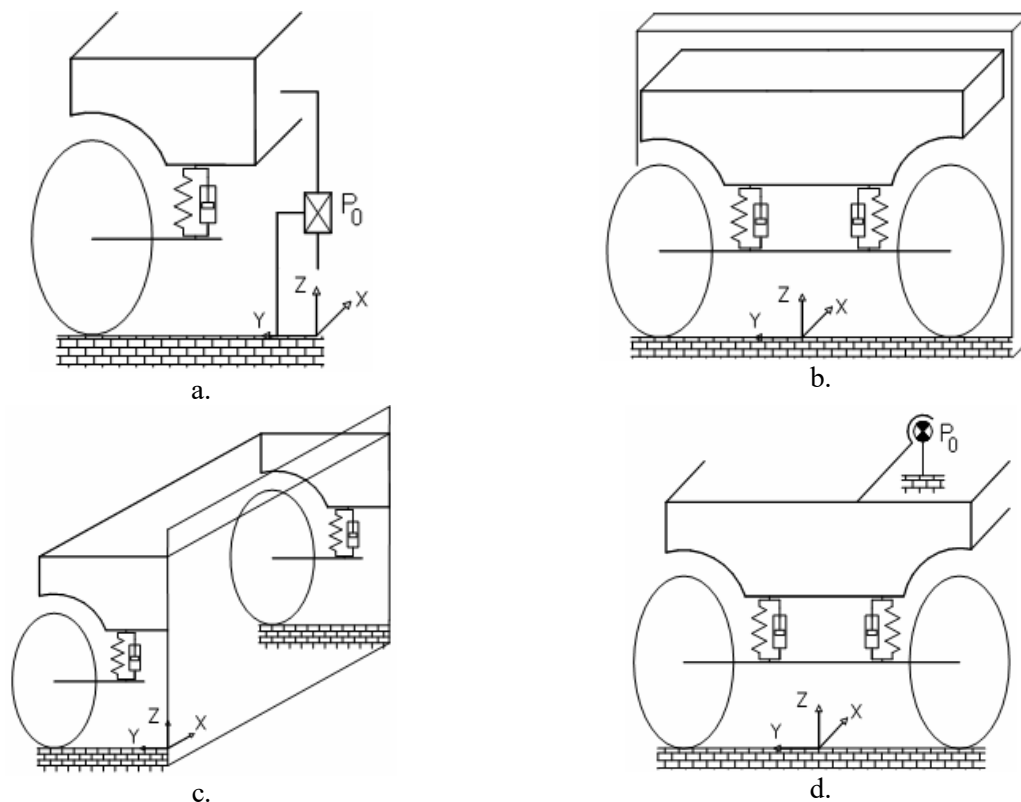

Figure 4. Quarter-vehicle and half-vehicle dynamic models.

For the half-vehicle model with spherical movement of the car body, the location of the spherical joint can be obtained based on the double-conjugate points method [9]. These points have the property that a force applied in one of them does not produce movement in the other, so each end (front and rear) of the car body executes oscillations around its own conjugate point. The main advantage of this model is that it allows the whole mass of the car body to be taken into account, similar to a full-car model (in terms of mass and inertia properties).

3. Results and discussion

As mentioned, for the purpose of comparative analysis, some of the previously presented dynamic models have been modelled and simulated in ADAMS by considering the dynamic with shock regime (see Figure 1,b), which is one of the standard tests in automotive industry for evaluating the comfort performance of the vehicles. The full-vehicle dynamic model, which is shown in Figure 5, contains the front wheels and rear axle suspension subsystems. The front wheels are guided by four-bar mechanisms, also called double-wishbone (Figure 6). The lower and upper guiding links (bars) are double-hinged to chassis by using bushings (also called flexiblocks), which are deformable joints with 6 elastic restricted mobilities [2], while the other ends of the links are hinged to wheel carrier by spherical connections. The same type of joints was used for the connections of the steering rods to the adjacent elements (wheel carrier and chassis). The guidance of the rear beam axle is assured by a so called "5S" mechanism (Figure 7), with four longitudinal bars and one transversal bar (named Panhard bar), which are connected to car body and axle by bushings.

The suspension subsystems also contain elastic and damping elements, namely springs, dampers and buffers limiting the suspension travel (extension - compression). The spring and dampers groups are concentrically disposed as shown in Figures 6 and 7, while the buffers are mounted inside the damper, thus limiting the relative movement between its elements. The values of the geometric, elastic and dissipative parameters that define the dynamic model correspond to an off-road car (ARO-type).

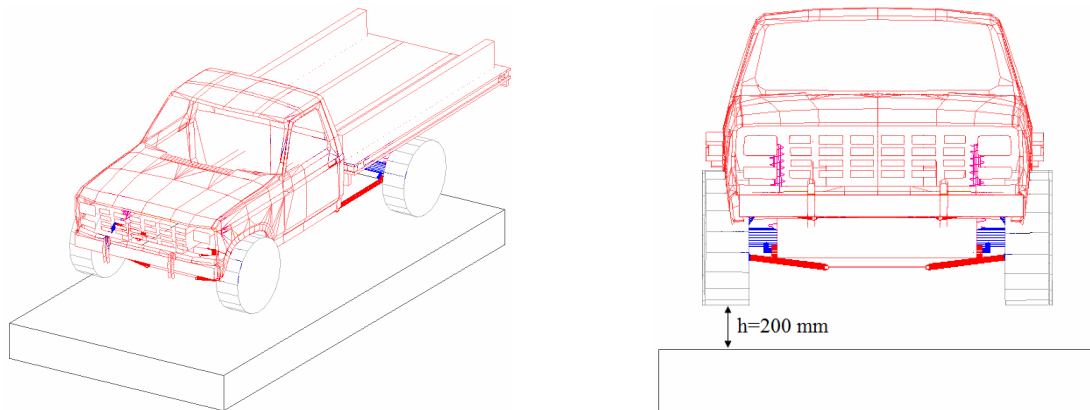

Figure 5. The full-vehicle dynamic model.

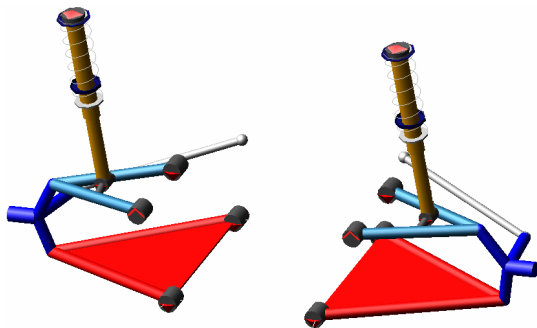

Figure 6. The front wheels suspension subsystem.

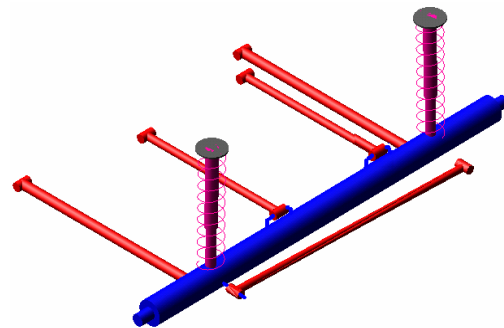

Figure 7. The rear axle suspension subsystem.

For the considered test, the vertical oscillation of the car body represents the main parameter by which the vehicle behaviour is evaluated. In the comparative analysis, the following models were considered: full-car, half-car, quarter-car, and linear half-car (without guiding mechanism). The half-car models (with and without guiding mechanisms) correspond to the front wheels (left & right) suspension, with spherical movement of the car body, according to the schemes shown in Figure 3,b and Figure 4,d. The quarter-vehicle model is corresponding to the left front wheel suspension mechanism, according to Figure 3,a and Figure 4,a.

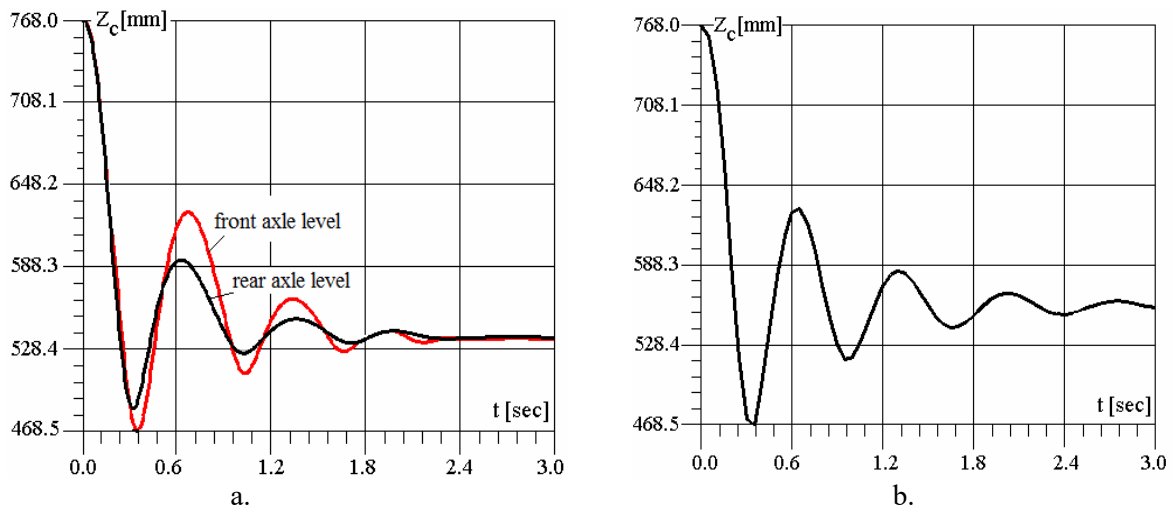

Figure 8. The vertical oscillations of the car body.

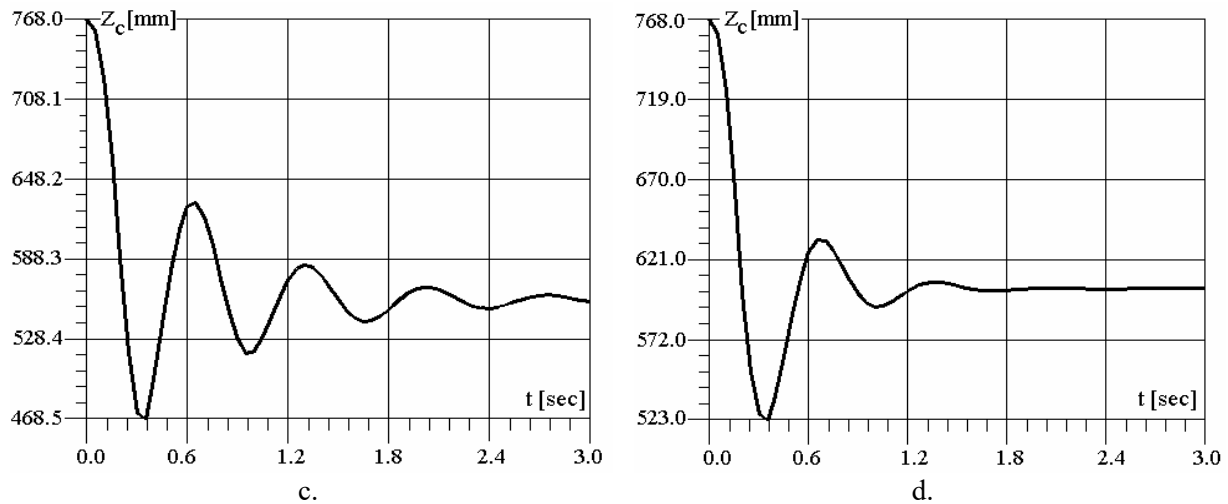

Figure 9. The vertical oscillations of the car body.

The results obtained through the dynamic analyses carried out in ADAMS are shown in Figure 8, reflecting the amplitudes and frequencies of the vertical oscillation/displacement (Z_C) of the car body, in its center of mass, as follows: full-vehicle (a), half-car (b), quarter-car (c), and linear half-car (d). These diagrams show that the half-car and quarter-car models provide very close results, being in good agreement with the full-car model (some differences, however small, occur in the amplitude of the oscillations). In contrast, the dynamic behaviour of the linear model differs from the one of the full-car model, both in vertical oscillation amplitude and frequency.

It can therefore be concluded that simplifying the suspension model by not considering the wheel/axle guiding mechanisms causes quite large errors in the dynamic analysis. On the other hand, the results show that the quarter-car model is the simplest viable model for studying the vertical oscillations of the car body, being able to successfully replace models with higher complexity.

4. References

- [1] Alexandru C 2009 The kinematic optimization of the multi-link suspension mechanism used for rear axle of the motor vehicle *Proceedings of the Romanian Academy - A* **10**(3) pp 244-253
- [2] Alexandru C 2019 Method for the quasi-static analysis of beam axle suspension systems used for road vehicles *Proceedings of the Institution of Mechanical Engineers, Part D: Journal of Automobile Engineering* **233**(7) pp 1818-1833
- [3] Knapczyk J and Maniowski M 2006 Elastokinematic modeling and study of five-rod suspension with subframe *Mechanism and Machine Theory* **41**(9) pp 1031-1047
- [4] Alexandru P, Macaveiu D and Alexandru C 2012 Design and simulation of a steering gearbox with variable transmission ratio *Proceedings of the Institution of Mechanical Engineers, Part C: Journal of Mechanical Engineering Science* **226** pp 2538-2548
- [5] Geonea ID, Alexandru C, Margine A and Ungureanu A 2013 Design and simulation of a single DOF human-like leg mechanism *Applied Mechanics and Materials* **332** pp 491-496
- [6] Ioniță M and Alexandru C 2012 Dynamic optimization of the tracking system for a pseudo-azimuthal photovoltaic platform *Journal of Renewable and Sustainable Energy* **4** pp 053117
- [7] Tarniță D, Catană M and Tarniță DN 2014 Contributions on the modeling and simulation of the human knee joint with applications to the robotic structures *Mechanisms and Machine Science - New Trends in Medical and Service Robots* **20** pp 283-297
- [8] Tarniță D, Catană M and Tarniță DN 2016 Design and simulation of an orthotic device for patients with osteoarthritis *Mechanisms and Machine Science* **38** pp 61-77
- [9] Guest JJ 1967 The main free vibrations of an autocar *Proceedings of the Institution of Automobile Engineers* **20** pp 505-548