

# Student Active Participation in the Study of the Light Bulbs

Petre Ogrutan<sup>1</sup>, Lia Elena Aciu<sup>1</sup>, Florin Sandu<sup>1</sup>, Carmen Gerigan<sup>1</sup>

<sup>1</sup> Transilvania University of Brasov, Electronic and Computers Department, 29, Eroilor Av, Brasov, Romania

**Abstract** – The paper presents an initiative approach to the study of light bulbs, involving active participation of the students engaged in interactive problem-/project-based learning of electromagnetic compatibility and energetic efficiency belonging to the environmental issues. The paper includes preliminary and complementary simulations of the hardware-firmware-software-netware development of a laboratory test bench for the study of conducted perturbations generated during the bulb firing sequence. This laboratory sub-system is useful both in association with traditional methods of learning as well as with e-Learning platforms. Finally, the paper presents the results of a concise survey of opinions on the outcomes of this research.

**Keywords** – Light bulbs, embedded systems, electromagnetic compatibility, engineering education.

## 1. Introduction

Energy saving and environmental protection are issues of high importance in modern society. Education of young people, especially of students in engineering, should face the challenges that lay ahead, so that environmental care should be a constant in their professional standing.

---

DOI: 10.18421/TEM54-03

<https://dx.doi.org/10.18421/TEM54-03>

**Corresponding author:** Lia Elena Aciu  
Transilvania University of Brasov, Electronic and Computers Department, Brasov, Romania  
**Email:** [lia\\_aciu@unitbv.ro](mailto:lia_aciu@unitbv.ro)

 © 2016 Petre Ogrutan et al, published by UIKTEN.

This work is licensed under the Creative Commons Attribution-NonCommercial-NoDerivs 3.0 License. The article is published with Open Access at [www.temjournal.com](http://www.temjournal.com)

The current technological context is characterized by continuous development of new electronic equipment and devices, of which most feature wireless communication facilities that have specific requirements regarding energetic efficiency and compliance with perturbation/susceptibility regulations. Lately, a pronounced tendency has been detected of focusing students' attention on environmental pollution issues and the effects of electromagnetic field on human health, as specified by European Community directives.

In a continuously changing world, in education process the emphasis should be moved from knowledge acquisition to deployment of abilities, thus meaning that the student should become active and deeply involved in his/her own learning process.

In the field of engineering, learning is more and more related to the use of information and communication technologies (ICT), leading to virtual laboratory work and teaching done by using the Internet and electronic courses. Students are enabled to acquire new knowledge and skills, whenever and wherever they have the possibility to do so (more vocational and ubiquitous), ensuring individualization of learning paths, too.

The *object* of study is represented by the light bulbs – an academic approach of their multidisciplinary issues regarding electromagnetic compatibility.

The *method* used is a synergy of "Agile" development with the interactive Problem Based Learning (PrBL) and Project Based Learning (PjBL).

The *subjects* are energy saving and environmental protection - the latter in terms of Electromagnetic Compatibility (EMC) and also regarding waste disposal.

The *apparatus* is enhanced with technical solutions accomplished by the authors and case studies that evaluate the environmental impact in terms of electromagnetic noise generated by conventional and electronically ignited lamps.

## 2. Light Bulbs

Since their invention by T.A. Edison, about 90% of the power consumed by incandescent bulbs is emitted as heat. Therefore, many governments have provided regulatory measures to discourage their use by establishing energy efficiency standards. Life of an incandescent bulb is about 1000 hours at least but, if used at a lower voltage than the nominal, life increases significantly. Nevertheless, operation of an incandescent bulb does not generate disturbances in power grid. No health problems relating to the use of incandescent bulbs have been reported.

Fluorescent bulbs (Compact Fluorescent Lamps, CFL) known as economic lamps, gradually started to replace incandescent bulbs due to their increased efficiency. The father of fluorescent bulbs is considered to be Peter Cooper Hewitt, who was the first to create such lamps in 1890. Replacing the conventional ignition system with an electronic circuit was a great step forward, lighting of the bulb became faster and flicker-free, thus, in 1985, OSRAM began selling light bulbs with an in-built electronic ignition system. The lifetime of fluorescent bulbs is 6-15 times longer than that of incandescent bulbs. Lifetime is significantly reduced if the light bulb is frequently turned on and off. Energy efficiency is higher compared with incandescent bulbs; for the same amount of emitted light energy, the overall energy consumption is 20% to 33% of incandescent bulbs consumption. According to data provided by the European Commission Scientific Committee on Emerging and Newly Identified Health Risks (SCENIHR), fluorescent bulbs may be harmful to human health due to the emission of ultraviolet and blue light. Light sensitivity may be an aggravating factor for people whose health is already affected. Much more environmental stress is produced by the presence of mercury vapors contained in the lamp tube. Therefore, in many countries fluorescent lamps are collected separately and recycled. When igniting these bulbs, current and voltage variations occur, producing conduction interferences with the electromagnetic environment.

A LED bulb consists of several LED (Light Emitting Diodes) that can be made of conventional or organic semiconductor materials (OLED). The lifetime of these bulbs is high, exceeding 30,000 hours.

Electroluminescence was discovered in 1907 by H.J. Round at the Marconi Laboratories. The first LED was created in 1962 by N. Holonyak at the General Electric Company. Technologies employed for the production of brighter LEDs follow an extremely dynamic trend. Similar to Moore's Law, R. Haitz devised a law that describes the evolution of

LED technologies. Haitz's law states that LED brightness doubles every three years beginning with 1960. In terms of EMC, LED bulbs lighting generates less noise compared with fluorescent bulbs. However, the built-in rectifier generates low-amplitude higher harmonics during its operation. Another major advantage in terms of environment protection is the absence of harmful substances (i.e. mercury) therefore LEDs are extremely environmental-friendly. The energy efficiency of LED lighting is very high and with the development of technologies for power LEDs, LED lighting becomes an option to be considered. Because of the comparatively high initial purchase price and the relatively low brightness level, LED bulbs are not so widely used as fluorescent lamps. One of the shortcomings of these lamps is their gradual decrease of brightness over time, a process aggravated at higher temperatures. As mentioned in [1], in 2010 an appliance manufacturer began equipping refrigerators with LED lamps, taking advantage of the specific brighter lighting at lower temperatures.

## 3. Educational methods

In recent times two modern directions in academic education were supported, one involving Distance Learning [2], [3] and another regarding PrBL/PjBL [4], the acquired expertise being applied to select the most adequate method for students' training.

Interaction with computer and laboratory facilities and active involvement of a learner in his/her own teaching process lead to the use PrBL and PjBL as interactive methods.

For PrBL, a largely accepted definition is "Problem based learning is an instructional method that challenges students to «learn to learn», working cooperatively in groups to seek solutions for real world problems" [5]. The main characteristics of PrBL are that learning is centered on the student, the teacher leaves the command, becoming an advisor, and the learning is done in steps, in small groups, having peer evaluation. The method may improve students' performance by collective work, encouraging critical and creative thinking, identifying the strengths and weakness of the learning, enforcing communication, managing skills and encouraging the use of different, real life resources, not only of academic resources.

For PjBL, the Project Management Institute [6] defines a project as a temporary endeavor in order to create a unique product, service or result. The three aspects of PjBL are [7]: individual study, team work and project execution, based on the competences and ideas obtained in former stages.

Many research papers reported successful results in applying interactive learning methods to the

Electrical Engineering. The paper [8], presents an interactive learning method encouraging students to freely express their opinions and promote individual work resulting in higher grades.

PrBL initiatives in education for Electrical Engineering were adopted worldwide, achieving better learning results compared to traditional learning [9]. Paper [10] is emphasizing the importance of computer simulations in PrBL for engineering. Paper [11] envisages the introduction of PrB in the first study year, regardless of the inherent difficulties of such an approach that is very different from the pre-academic traditional education. An important issue for the success is the attractiveness of the theme [12] and the freedom of action and responsibility given to students, similar to the one presented in [13]. But the most challenging enhancement of PjBL was the implementation of “Agile development” [14] – we involved active students’ participation in various roles: presumptive customers/ beneficiaries in the “technical consultancy” preliminary phases, presumptive architects participating at the accomplishment of level 1 functional specifications and of the *symmetric* validation/acceptance procedures, presumptive experts participating at the integration tests.

The present paper is based on an educational experiment using PrBL and PjBL techniques that we conducted in the academic year 2013-2014 on 80 undergraduate students at the third year in Applied Electronics and Telecommunication Systems and Technologies from the Faculty of Electrical Engineering and Computer Science.

#### 4. The interactive approach to PrBL

In order to accomplish the instructional design for the study of light bulbs, PrBL was applied, being pursued the following steps – a heuristic procedure developed by the authors [15] aiming to actively involve students in conception-analysis-synthesis-interpretation phases.

##### *Phase 1: Clarifying the subject and concepts*

After providing brief theoretical overview, the lecture materials on the construction principles and characteristics of the lamps were discussed with a focus on three types of lamps characteristics (Table 1) in terms of environmental (including electromagnetic) compatibility. The data provided in Table 1 are indicative approximations and were determined through discussions with the students.

*Table 1. Main lamp characteristics - Comparison*

Characteristics	Incandescent lamp	Fluorescent lamp	LED lamp
Cost [€]	1	5	10
Power [W] for 1000 lm	100	15	10
Lifetime [h]	1000	6000	100000
Disposal	No hazards	Mercury leakage	No hazards
Intensity variation	YES	NO	NO
Electromagnetic disturbances	NO	At start and during operation	During operation

##### *Phase 2: Defining the subject and identifying the problem*

After clarification of the concepts, the main problems of light bulbs were stated in terms of lighting efficiency (a) and EMC (b).

The problems that need to be solved can be formulated as answers to the questions (a): *Which bulb is more light efficient?* (b) *Do the bulbs produce electromagnetic disturbances? How can these be assessed?*

##### *Phase 3: Analysis of the problem*

This phase was performed through team-work – the discussions were aimed to stimulate students’ imagination.

(3.a) To the question *Which bulb delivers a better light?*, it popped-up the idea of evaluating the quality of lighting by analyzing a photo of the light bulb and of the interior of a white box it illuminates [16]. What proved to be very relevant was the gray scale histogram - the students pointed out that such a histogram has the advantage to be obtainable using almost any type of digital camera and almost any type of general-purpose image processing software available. The three lamps were photographed (using a typical mount) in the white box (they are presented in Figure 1 – each one accompanied by its histogram). The photos, taken with a 16 Mega Pixel camera, were transformed into a gray scale with 256 levels (0 for black to 255 for white) – the abscissa of the histograms. For each abscissa, the ordinate of the histogram corresponds with the number of pixels having that level of gray (*normalized* to the maximum – so the max. ordinate is 100%, as reference also to the *Median* ordinate).

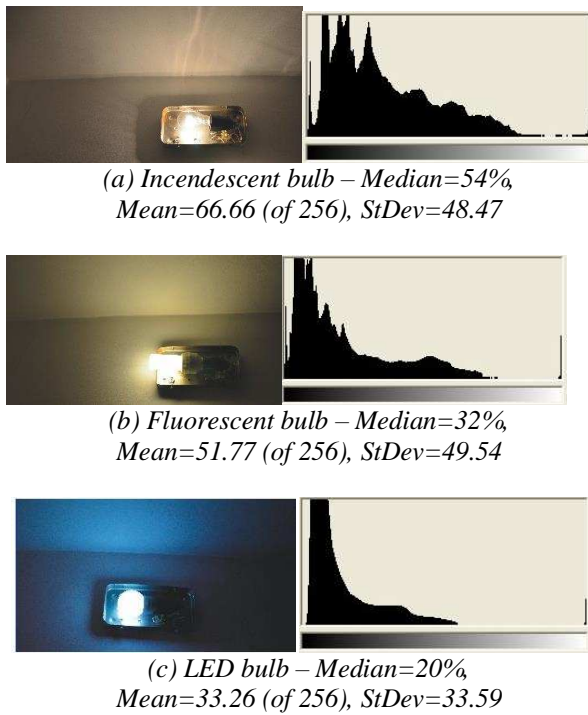

Figure 1 – 16MP pictures of the incandescent (a), fluorescent (b) and LED (c) bulbs, with their histograms

(3.b) To the questions *Do the bulbs produce electromagnetic disturbances? How can these be assessed?*, the considered literature [17, 18] and the discussions were focused on laboratory testing, a very useful approach, as most of the compatibility regulations are accompanied by the specifications of standard test-setups and by precise measurement procedures.

It was also revealed that the possibility of disturbances occurring during lamp firing depend on the instantaneous amplitude of mains voltage.

*Phase 4: Synthesis and interpretation of newly acquired information*

(4.a) During this phase, pictures of incandescent, fluorescent and LED bulbs were taken. The image processing was performed and the distribution of gray levels was illustrated numerically by the *Mean* abscise and by the *Standard Deviation* (e.g. the LED bulb has a smaller StDev, then a more concentrated spectrum).

A possible use-case of LEDs for street lighting [19] was discussed with the students, emphasizing the opportunity of a laboratory reproduction of outdoor operation.

(4.b) The assessment of light bulb electromagnetic disturbances involves two steps which are: Simulated experiments (4.b.1) and Laboratory experiments (4.b.2).

(4.b.1) The computer-aided simulation was proposed by the students and was carried out together

with the authors in their “tutor’s role”. The students were assigned individual tasks, to perform simulations of a power grid “line filter”, using components with known specifications, so as to diminish the amplitude of voltage impulses occurring during light bulb ignition. After completing this activity, disturbances generated by different types of bulbs were measured on a laboratory test workbench, thus adding practical knowledge to the theoretical engineering aspects of the taught subject.

As the importance of computer simulation in understanding the phenomena is unquestionable, the approach presented in [20] – using *at least two* simulation programs and comparing the results – was also considered. The power line filter was complying with IEC 939 Schaffner [21] and EN 133200 [22]. The electric diagram of the filter is presented in Figure 2.

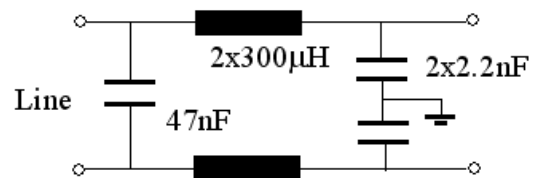

Figure 2. Line filter electric diagram

Most of the students used SIMULINK and PSPICE to perform their simulations. One of the best SIMULINK models developed by a student (that was assessed and corrected by the tutors) uses a sinusoidal signal, superposed over a single pulse of 500V amplitude and 2µs length applied as an input signal. The SIMULINK simulation waveform is shown in Figure 3.

It can be noticed that the filter diminishes impulse amplitude to about 100V but increases its length.

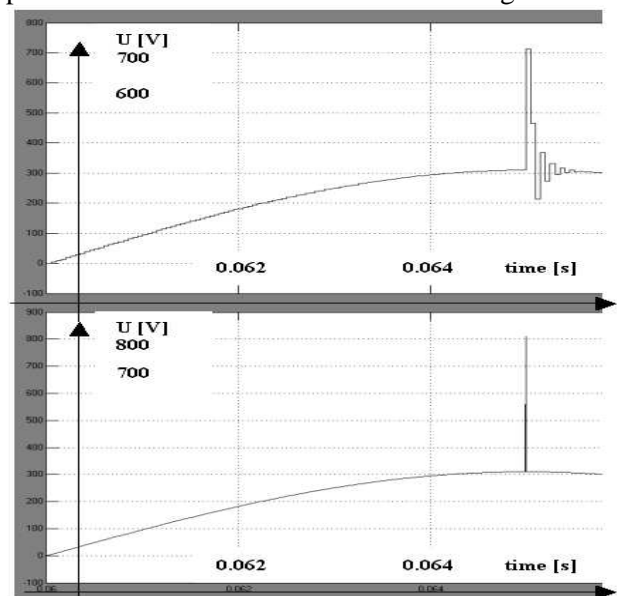

Figure 3. Line filter SIMULINK simulation result: output (top) versus input (down)

The same electric schematic was used to perform the second simulation, in PSPICE. The simulation waveform is shown in Figure 4.

As it can be seen, the two simulations provided close results (in duration, amplitude and shape of the I/O pulses).

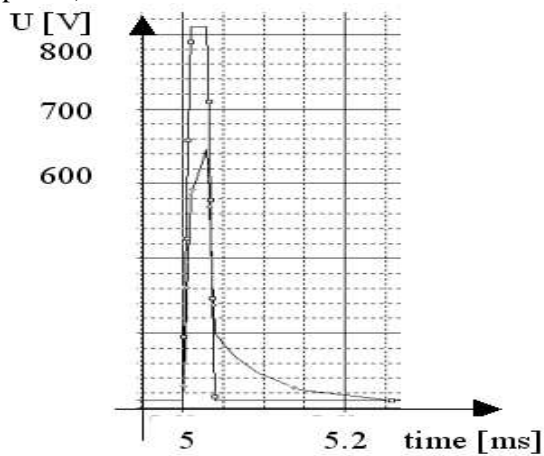

Figure 4. PSPICE simulation waveforms

Discussions with the students showed that they acknowledged usefulness of simulation techniques, a conclusion that has been confirmed by the results presented in [4]. For a high degree of visualization, enabling intuitive interpretation, plotting of the phenomena was done both in the time domain and in the frequency domain. Having the spectrum of the synthetic pulse, the students were asked to simulate the frequency characteristic of the required line filter. This task implied good knowledge of Analog Electronics and was easily accomplished. Figure 5 shows the PSPICE frequency characteristic.

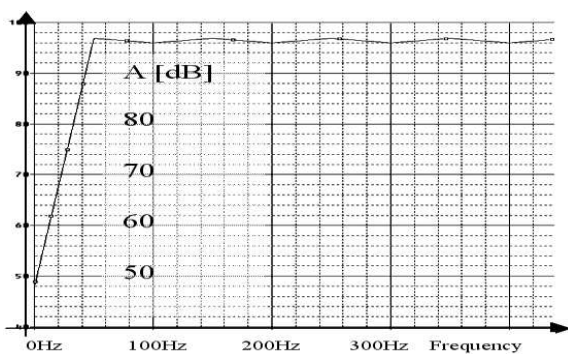

Figure 5. PSPICE line filter characteristic

(4.b.2) The laboratory session started with the preparation of a test workbench equipped with several standard sockets (for different types of bulbs) and electronic ignition systems (for conventional fluorescent bulbs). An oscilloscope was used to visualize waveforms during and after lamps ignition. Some typical voltage waveforms for a CFL during ignition and after bulb heating are shown in Fig. 12.

The high amplitude peak voltage occurs when the CFL is ignited and the subsequent wave distortion

generates higher harmonics in the mains supply line. A comparison between different bulbs shows that the highest amount of electromagnetic disturbances is generated by the fluorescent bulb and the lowest by the incandescent one.

A major disadvantage of the initial laboratory experimental setup has been identified together with the students (this phase was discussed also as the preliminary step that is triggering the Agile development process).

The amplitude of externally induced disturbance was supposed to be influenced from the moment the light switch is flipped on, that is, by the instantaneous value of the AC voltage. To avoid this uncertainty, an electronic switch was proposed, so as to ensure bulb ignition only when the AC voltage reaches its peak value.

An indirect confirmation of this hypothesis was provided by simulations of voltage events in the power supply network, which are more relevant when the AC voltage reaches its peak value [23].

## 5. PjBL- Microcontroller Subsystem for Supply Coupling and Internet Transmission of Data

The block diagram of the microcontroller-based system – with industrial applicability for optimal supply coupling and remote monitoring – was proposed as a project by the academic staff members during their discussions with the students – the Agile development phase of “agreement on the architecture” of a solution. This approach aims to get the students acquainted with the dynamic and iterative customer-developer-tester relationship in modern projects with a complexity beyond the classical “waterfall” model. The feasibility of the solution was assessed by preliminary simulations carried out by the students working together with the authors. Having as outcome the functional specifications for the first part of PjBL, this teamwork had also a secondary goal of enhancing group communication and developing inventiveness in technical solutions. This secondary goal is regarding not only some drawbacks of individual assessment in education (usually per person and not per team) but also some traditional communication problems of the engineers and students in engineering (by involving them in the Agile “Scrum”). The next phases – further development and module tests (level 2) of the embedded subsystem – were accomplished by the authors involving the students in the Agile phases of integration (level 1) and validation tests.

*Phase 1: Models and simulations of supply coupling*

A straightforward SIMULINK model was developed, as seen in Figure 6: The model consists of a voltage source (mains line) and an ideal switch that connects the supply to a RL load. The switch is controlled through 5 pulses before stabilizing the applied voltage, which simulates electro-mechanic contact bouncing. The simulation goal was to study two usual switching strategies: the load coupling to the supply at its AC voltage zero crossing (Figure 7.a) or at its AC voltage peak – at the positive semi-sinusoid midpoint (Figure 7.b).

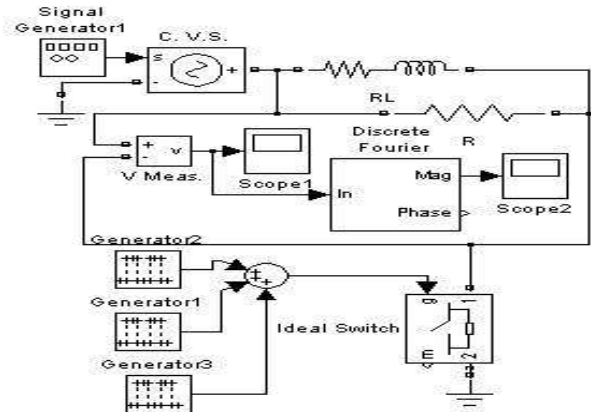

Figure 6. SIMULINK model of supply coupling

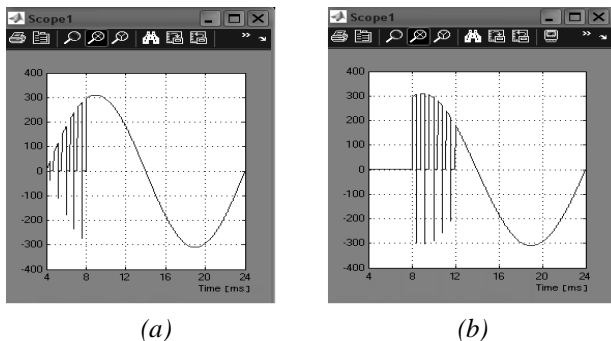

Figure 7. Simulation results in case of supply coupling at AC voltage zero crossing (a) and at AC voltage peak (b)

From the time-domain simulation, it can be observed the larger amplitude of the negative disturbing pulses in the second case (as expected considering that overshoots are caused by higher switching-bouncing levels) (b). The frequency-domain simulation – via the Discrete Fourier transform block in the middle of the SIMULINK diagram – confirms the occurrence of higher spectral amplitudes when coupling the supply at AC voltage peak value, thus confirming the advantages of the first coupling scenario (a).

*Phase 2: Design and implementation of an embedded system with remote control via Internet*

The block diagram of the voltage supply coupling sub-system is shown in Figure 8.

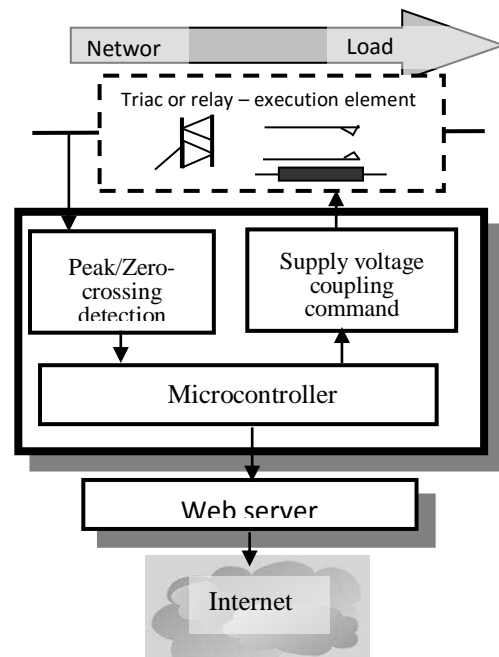

Figure 8. Remote-controlled voltage supply coupling sub-system (block diagram)

The implemented module is an embedded sub-system based on a PIC microcontroller. Microcontroller interrupts are generated always at mains network voltage zero-crossings, thus allowing for the setting of voltage coupling-time and control of the execution element. Two versions of the sub-system were developed and tested; one provided with a triac and another with a relay as execution elements.

The triac version employed a 24A/800V triac controlled by an opto-triac providing galvanic decoupling. A snubber circuit prevents the parasitic priming of the triac and a varistor ensures triac voltage surge protection.

To provide triac phase control, mains voltage zero crossing is signaled to the microcontroller through an *interrupt*. The problems arising in this case relate to a certain zero-crossing detection delay and the time needed by microcontroller routine execution to generate a priming impulse. These two processes introduce a priming delay to the triac.

To determine the admissible delay, the RMS value of the voltage can be calculated for a  $\pi/4$  phase angle firing of the triac, as shown in Figure 7, using following relationship (1):

$$U_{ef} = \sqrt{\frac{1}{T} \int_0^T u^2 dt} = \sqrt{\frac{(230 \cdot \sqrt{2})^2}{2 \cdot \pi} \cdot 2 \int_{\pi/4}^{\pi} \sin^2 \varphi \cdot d\varphi} \quad (1)$$

Performing the calculations yields an effective value of 209.73V, which is acceptable.

This delay allows for 25% maximum theoretical error of zero-crossing detection or running a number of instructions over the 2.5ms interval that is, up to several hundreds of instructions. For example, with a RISC microcontroller processing one instruction per cycle at a 1MHz clock frequency, one thousand instructions per millisecond can be executed.

To ensure the highest possible RMS value, the zero-crossing detection delay must be kept as small as possible. The triac provided superior performance since it assured a more precise coupling time, yet the fact that turn-off time is uncontrollable and for certain types of loads the switching is unsafe represents a drawback.

The relay version eliminates the disadvantages of the triac but whenever a relay is employed, the specified closure and release times must be considered and fine adjustments should be applied after repeated trials. After testing both versions, the relay version was selected for its additional advantages, so it is the one detailed in the following.

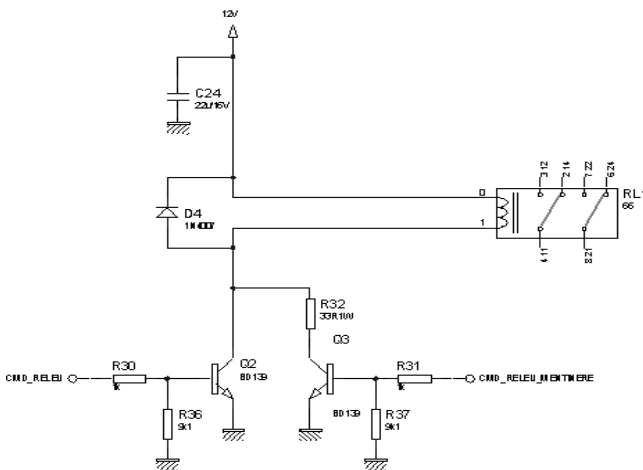

Figure 9. Electronic circuit for relay control

The relay was designed for coupling/decoupling of the load, as can be seen in Figure 9. The control signal switches the Q2 transistor (left) into saturation, energizes the relay, and, after one second delay, a new command is transmitted turning transistor Q3 (right) into saturation, thereby connecting a current-limiting resistor in series with the relay. Thus, transistor Q2 is cut off. The starting high current command ensures firm and fast closure of the relay contacts.

The relay chosen for this applications manufactured by FINDER and features 30/50A (rated current/peak current) and 250/440V, while the relay coil can be controlled with either 6 or 12V. Typical relay life cycle is up to 1000cycles. Basic closure time of relay contacts is 8-10 ms. As for the

microcontroller, we have chosen PIC18F452 connected in its standard configuration. Evaluation of mains voltage and load current consumption as well as setting the accurate timing for coupling and decoupling was achieved by timer interrupt (Timer 2), which is initialized for every supply voltage zero crossing. Figure 10 presents the timing diagram of the microcontroller program.

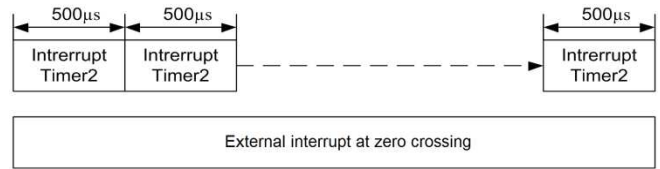

Figure 10. Timing diagram of the microcontroller program

Similar achievements that include switching mains voltage to the load at given times are widely used in UPS (Uninterruptible Power Supplies). When the mains supply voltage is restored, the UPS applies the load a voltage of identical polarity on the rising front of the pulse slope like the voltage provided by the DC-AC converter during the absence of the mains voltage. A switching control algorithm is described in [24] and the hazard related to the occurrence of a short switching interval when the voltage is supplied both by the mains as well as by the DC-AC converter is described in [25].

One of the most important design features discussed in the initial Agile phases and derived as functional specification during PjBL is the remote monitoring and control of the microcontroller-based subsystem via Internet. Various software applications ensuring the remote connection of several devices were considered – such a solution including a power supply is described in [26].

Our dedicated solution is based on a “Site Player” – a web server handling Ethernet packets and having a programmable IP (we have used 193.123.23.200). The communication between the Site Player and the host microcontroller-based embedded system is accomplished over the RS232 interface. The eight I/O lines of the embedded system are thus monitored controlled over the Internet via the Site Player. The web page it publishes contains a report with the coupling and decoupling times as well as the coupling and decoupling commands.

## 6. Validation Tests in the Laboratory

The validation tests (corresponding to the Agile “acceptance” phase) of the system for intelligent coupling for different types of light bulbs were performed in the laboratory. The disturbances generated during ignition were measured in experimental sessions together with the students.

Incandescent bulbs, halogen bulbs, fluorescent lamps with electronic and conventional ignition and LED bulbs were studied – all in different sizes and with various power ratings.

As expected, the experimental results confirmed that when lighting an incandescent bulb, the voltage waveform is completely disturbance-free since the bulb represents a purely resistive load.

For a better comparison of the lamps, the most stressing coupling scenario was chosen, the second one, with the AC voltage being applied at its mains peak value (at 90 degrees of mains phase) – as displayed on the digital oscilloscope screen shown in Figure 11.

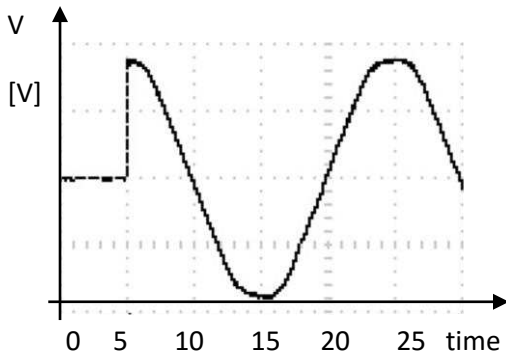

Figure 11. Voltage on an incandescent bulb at controlled ignition

Lighting a fluorescent lamp with conventional bimetal starter generates a high amount of disturbances, as can be seen on the voltage waveform presented in Figure 12.

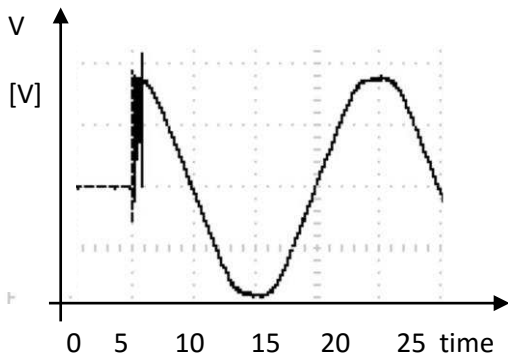

Figure 12. Voltage on a CFL with bimetal starter at controlled ignition

A fluorescent bulb with electronic ignition produces lesser disturbance – it can be seen in Figure 13, for a 24W bulb. To reduce the disturbance generated in the mains network, line filters (initially used only in simulations) are now employed. The test workbench was equipped with a Schaffner filter compliant with the IEC 939 and EN 133200 standards. For example, the effects of the line filter are presented in Figure 14, for the case of new street lighting power LEDs (LLM4500, 51Watt).

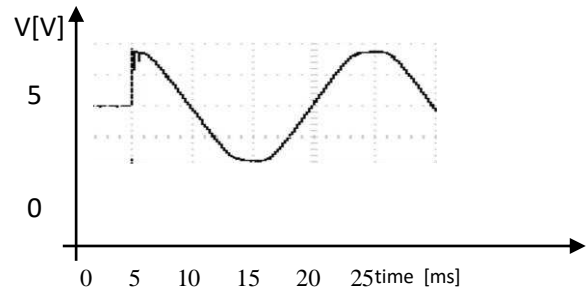

Figure 13. Voltage waveform on a CFL with electronic starter at controlled ignition

The output of the filter (at the side of the mains line) is on Channel 1 of the digital oscilloscope (upper waveform of Figure 14) and the lamp voltage, the filter input, is on Channel 2 (lower waveform of Figure 14), having a pronounced initial spike that can be clearly observed (and that would highly perturbative in case of the missing line-filter).

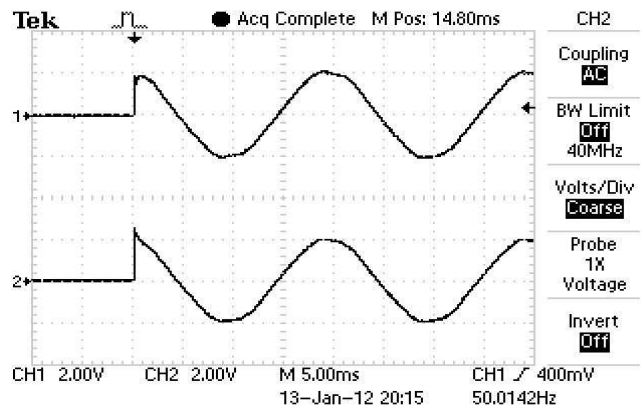

Figure 14. Ignition of a street lighting lamp with LEDs and line filter

## 7. Discussions and Results

Educational results – in terms of a validated instructional design – are represented by a reusable didactical pattern of PrBL and PjBL, able to be extended for newer added-on sub-systems in the next academic years.

The procedures were documented, as laboratory guides for real or simulated/emulated experiments.

Similar findings in the specialized literature were confirmed: discussing work efficiency, a special aspect was that some activities were optional; the learning paths had a certain degree of freedom and a flexible schedule, thus avoiding demotivation [27].

The importance of performing computer simulations for this kind of complex PrBL/PjBL confirmed the idea of Wei-Hsin Liao et al. who proposed in [28] an advanced simulation course for final year students (not only a practical introduction in simulation, elementary course for the first years of engineering studies).

Our approach also confirmed the trend that endorses importance of joint debates and teamwork [29-31] for multidisciplinary subject (as EMC) taught to students who prepare their graduation work.

In order to evaluate the impact of the PrBL and PjBL methods proposed, the students of the target group were asked to participate in an anonymous and voluntary survey.

The survey results are summarized in Figure 15. The questionnaire contained 4 questions, each of the answers being rated from 1 to 5. A number of 51 students participated in the survey.

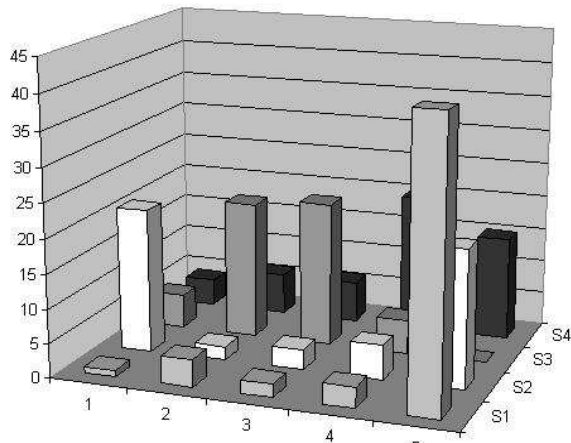

Figure 15. The survey results

The first question (S1) was "How important is, in your opinion, the present-day problem of energy saving and environmental protection". Answers ranged from 1 (unimportant) to 5 (very important), and are represented on the first line (S1) of Fig. 15. Most students (80%) were 'sensing' the issue of energy saving as being important.

For the second question (S2) "How do you appreciate the usefulness of the individual work"; the answers ranged from 1 - I haven't done my homework, 2 - unnecessary to 5 - very useful (individual task).

Only 60% of students completed their individual tasks – out of them, a significant percentage (67%) considered it a very important topic.

For the third question (S3) "What type of bulb would you use in your home?" the answers ranged from 1 - incandescent, 2 - fluorescent, 3 - LED, 4 - I don't know; most chose equally (40%) LED and fluorescent bulbs. 10% chose incandescent bulbs arguing that the light intensity does not vary after lamp ignition.

For the fourth question (S4) "How important is, in your opinion, the environmental aspect when choosing a light bulb"; answers ranged from 1 - not important to 5 - very important. Most respondents (40%) checked level 4, which is slightly different from the answers to question 1.

The results are in line with those provided in [32], where there are addressed user perceptions about the same three types of light bulbs that were examined in our paper.

People's awareness is rising toward environmental issues through saving lighting costs. The use of new economy lamps helps protect the environment and at the same time ensures financial savings [33].

## 8. Conclusion

The environmental aspects of light bulbs are rather complicated if EMC criteria are completed with energy efficiency, impact on the health, disposal problems etc. This is the reason we have chosen to involve directly subjective aspects in the evaluation of the lamps, of the technical measures to improve their environmental friendliness and their testability. The educational approach and direct participation of students in electrical engineering resulted in modern methods of study and original solutions for the laboratory workbenches with Internet access.

Many students nowadays complete the individual activities with team-work that can bring more confidence by joint discussions under teaching-staff mediation, insisting on differences between participants' opinions.

Some positive aspects regarding PrBL and PjBL in environmental education were confirmed:

- Sensitization of the students to the environmental issues and introducing the notion of „green engineering”;
- Teamwork training
- Development of creativeness and ingenuity, required for phenomena simulation.

The student workgroups integrated quite well in this type of training, the obvious advantages being team spirit, exercise of deadline setting and keeping, discovering the benefits of brain-storming sessions and developing competences through close-up study of high-tech solutions.

The greater interest levels shown by many students were justified by the "vocational" character of the chosen discipline – some challenging technical problems even raised their enthusiasm and teamwork contributed to overcome theoretical and practical difficulties.

Following modern Agile development principles, we promoted the synergy of PjBL with collaborative methods, thus transcending peer-support towards *innovation-pushing*.

Simulation/emulation (including double-check with different methods) was used for the evaluation of dedicated testing methods and configurations, as high voltages and special pulse generation are usually needed in EMC laboratories. Time-domain

and frequency domain analysis was done both with virtual and real equipment (e.g. line filters), comparing different source-coupling scenarios.

An "intelligent coupling" system, with AC voltage peak/zero-crossing detection, rapid triggering (interrupt generation) was designed, implemented on the basis of a micro-controller and tested with various light bulbs (of different types and powers). The micro-controller also drives a serial interface with a web-server that is publishing the control / status of the 8 I/O lines of the lab workbench. This implemented remote access to the developed laboratory workbench is not only a potential technical feature for tele-monitoring and control (via Internet) in Smart Grids (e.g. street lighting networks of modern cities) but is also a specific enabler of ODL (Open and Distance Learning) in electrical engineering [34].

## References

- [1]. Cangeloso, S. (2012). *LED Lighting*. O'Reilly publishers.
- [2]. Cagiltay, N.E., Aydin, E., Oktem, R., Kara, A., Alexandru, M., Reiner, B. (2009). Requirements for remote RF laboratory applications: An educators' perspective. *IEEE Transactions on Education*, 52(1), 5-81.
- [3]. Moraru, S.A., Ungureanu, D., Sandu, F., Grigorescu, C., Krupka, L. (2008). Solutions for developing and integrating software tools for e-Learning systems, *Annals of DAAAM for 2008*, 905-906.
- [4]. Ogrutan, P.L., Aciu, L.E., Gerigan, C., Romanca, M. (2010). Environmental education in Electrical engineering. *Environmental Engineering and Management Journal*, 9(9), 1187-1194.
- [5]. Duch, B. J., Groh, S. E., Allen, D. E. (2001). *The power of problem based learning*. Stylus Publishing.
- [6]. *A Guide to the Project Management Body of Knowledge*. Project Management Institute-On line.
- [7]. Wedlund, T., Axelsson, K., Melin, U. (2006). Project-Oriented Education- Managing Three Simultaneous Processes, *Proceedings of the International Research Conference* online: [http://www.lancs.ac.uk/fss/events/hecu3/documents/wedlund\\_axelsson\\_melin.doc](http://www.lancs.ac.uk/fss/events/hecu3/documents/wedlund_axelsson_melin.doc)
- [8]. Savander-Ranne, C., Lunden, O. P., Kolari, S. (2008). An alternative teaching method for electrical engineering courses, *IEEE Transactions on Education*, 51, 423-431.
- [9]. Mantri, A., Dutt, S., Gupta, J.P., Chitkara, M. (2008). Design and evaluation of a PBL-Based course in analog electronics, *IEEE Transactions on Education*, 51, 432-438.
- [10]. Tarek, A.T., Ashraf, S., Saber, R. (2009). An undergraduate mechatronics project class at Philadelphia University, Jordan: Methodology and experience, *IEEE Transactions on Education*, 52, 365-374.
- [11]. Montero, E., Gonzalez, M. J. (2009). Student Engagement in a structured problem- based approach to learning: A first-year electronic engineering study module on heat transfer. *IEEE Transactions on Education*, 52, 214-221.
- [12]. Firebaugh, S., Piepmeier, J. (2008). The RoboCup nanogram league: An opportunity for problem-based undergraduate education in microsystems. *IEEE Transactions on Education*, 51, 394-399.
- [13]. Max L., Thiringer T., Undeland T., Karlsson R. (2009). Power electronics design laboratory exercise for final-year M. Sc. Students. *IEEE Transactions on Education*, 52, 524- 531.
- [14]. Highsmith, J. (2009). *Agile Project Management: Creating Innovative Products*. Addison-Wesley Publishing House.
- [15]. Schmidt, H. (2004). *The rationale behind problem based learning*, online: [http://www.cfbd.asso.fr/\\_dwdl\\_public/jh/2004/2004\\_Avignon\\_rationale.pdf](http://www.cfbd.asso.fr/_dwdl_public/jh/2004/2004_Avignon_rationale.pdf)
- [16]. Ogrutan, P.L., Gerigan, C. (2004). Project Based Learning in Environmental Education Light Bulbs - Case Study. *Proceedings of the 13<sup>th</sup> International Conference on Optimization of Electrical and Electronic Equipment*, 1331-1336.
- [17]. Coca, E. Popa, V., Buta, G. (2011). Compact fluorescent lamps electromagnetic compatibility measurements and performance evaluation, *Proceedings of the IEEE International Conference on Computer as a Tool*, 1-4.
- [18]. Buta, G., Coca, E., Graur, A., Popa, V. (2010). Performance Evaluations and Comparative Electromagnetic Compatibility Measurements on Compact Fluorescent Lamps. *Proceedings of the 10<sup>th</sup> International Conference on Development and Applications Systems*, 289-293.
- [19]. Lauric, S., Pentiuc, R., Ivanov, N. (2011). Designing a road lighting system. *Acta Electrotehnica*, 52(5), 237-243.
- [20]. Pitica, D., Lungu, S., Pop, O., Ciocan I. (2006). Matlab based platform for anti-perturbative design of digital connections. *Proceedings of the 1st Electronics System integration Technology Conference*, 655-660.
- [21]. IEC - International Electrotechnical Commission - IEC 939: Filter Units for Radio Interference Suppression, online: [www.iec.ch](http://www.iec.ch)
- [22]. CENELEC - European Committee for Electrotechnical Standardization - EN 133200: Harmonized system of quality assessment for electronic components. Sectional specification: passive filter units for electromagnetic interference suppression, online: <http://www.cenelec.eu>
- [23]. Istrate, M., Miron, A., Istrate, C., Gusa, M., Machidon, D. (2009). Single-phased Fault Location on Transmission Lines Using Unsynchronized Voltages, *Advances in Electrical and Computer Engineering*, 3, 51-56.
- [24]. Li, Y., Hong-Tao, J. (2011). Research of a new type series-parallel converted UPS circuit and its control strategy, *Proceedings of the IEEE International Conference on Consumer Electronics, Communications and Networks*, 1560 – 1563.
- [25]. Brown, W.A., Kennedy, J. M., Linkhart, C. (2010). Investigation of circulating ground currents occurring during UPS/generator paralleling, *Proceedings of the IEEE Industrial and Commercial Power Systems Technical Conference*, 1-9.
- [26]. Ciubotariu. C. (2004). Work in progress - using Internet applications to control remote devices for an instrumentation laboratory. *Proceedings of the 34<sup>th</sup> Annual Frontiers in Education*, T1H-24- T1H-29.
- [27]. Mendez, J.A., Gonzales, E. (2011). Implementing Motivational Features in Reactive Blended Learning: Application to an Introductory Control Engineering Course, *IEEE Transactions on Education*, 54 (4), 609-627.

- [28]. Wei-Hsin Liao, Shun-Chung Wang, Yi-Hua Liu. (2012). Generalized Simulation Model for a Switched-Mode Power Supply Design Cours Using Matlab/Simulink. *IEEE Transactions on Education*, 55(1),36-47.
- [29]. Sandu, V., Ambrus, C. (2009). Problem based learning - case study for automotive engineering. *Proceedings of the 13 th International Conference Modern Technologies, Quality and Innovation, Modtech*, 571-574.
- [30]. Jegelevičius, D., Pagodinas, D., Dumbrava, V. (2010). Laboratory Experiments in Circuit Theory: Link between Theoretical Concepts and Practical Examples. *Electronics and Electrical Engineering Journal*, 6(102), 107-110.
- [31]. Mihailov, D., Sudnitson, A., Kruus, M.(2010). Project-Oriented Approach to Low-Power Topics in Advanced Digital Design Course. Examples. *Electronics and Electrical Engineering Journal*, 6(102),151-154.
- [32]. Stall-Meadows, C., Hebert, P.R. (2011). The sustainable consumer: an in situ study of residential lighting alternatives as influenced by infield education. *International Journal of Consumer Studies*, 35(2),164-170.
- [33]. Slocum, R. (2004). Polar bears and energy- efficient light bulbs: strategies to bring climate change home. *Environment and Planning: Society and Space*, 22.413-438.
- [34]. Atef, H., Medhat, M. (2015). Blended Learning Possibilities in Enhancing Education, Training and Development in Developing Countries: A Case Study in Graphic Design Courses. *TEM Journal – Technology Education Management Informatics*, 4(4), 358-365.