

PAPER • OPEN ACCESS

## Static analysis of a vehicle suspension with leaf springs and reaction bars

To cite this article: C Alexandru 2020 *IOP Conf. Ser.: Mater. Sci. Eng.* **898** 012038

View the [article online](#) for updates and enhancements.

You may also like

- [Optimization of Various Percentage of Fibers in Fiber Reinforced Composite Material Leaf Springs in Vehicles](#)  
Shivam Aggarwal, M. L. Aggarwal and Krishan Verma
- [Investigation on the effects of changing automotive vehicles leaf springs from steel to hybrid polymer composite leaf springs](#)  
Vijayalakshmi P, Pazhanivel K, Praveen Raj P et al.
- [A small robust monolithic vacuum-compatible microbalance with automated calibration: achieving high accuracy with a large load capacity](#)  
R F M Martens, O van der Sluis, M G D Geers et al.



**UNITED THROUGH SCIENCE & TECHNOLOGY**

 **The Electrochemical Society**  
Advancing solid state & electrochemical science & technology

**248th  
ECS Meeting**  
Chicago, IL  
October 12-16, 2025  
*Hilton Chicago*

**Science +  
Technology +  
YOU!**

**Register by  
September 22  
to save \$\$**

**REGISTER NOW**

# Static analysis of a vehicle suspension with leaf springs and reaction bars

**C Alexandru**

Transilvania University of Braşov, Romania

E-mail: calex@unitbv.ro

**Abstract.** The work approaches the static analysis of a suspension mechanism with leaf springs and reaction bars used for motor vehicles. The reaction bars are used for compensating the twist of the springs into an 'S' shape, a phenomenon that occurs in the classic suspension system with soft leaf springs during hard acceleration or braking. The virtual prototyping software package ADAMS is used for modelling and simulating the suspension system. The static analysis results reveal the improved behaviour of the suspension system with reaction bars relative to the classical leaf spring suspension system.

## 1. Problem statement

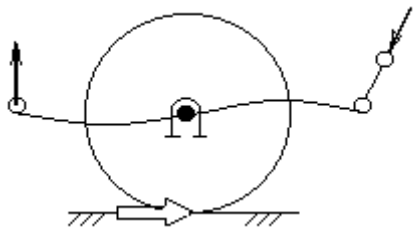
The automotive industry is one of the most important and performing economic branches, the technical-material resources oriented to this field constituting peaks of current technology. If in the first vehicles, the main problem was self-propulsion, with the emergence and development of internal combustion engines, the car manufacturers' researches were oriented both towards optimizing the form (design) and improving the dynamic performance of the vehicle, in terms of stability, comfort, manoeuvrability and reliability.

In the relative motion to car body (chassis), the vehicle wheels can be guided independently - by means of a guiding mechanism for each wheel (independent suspension), or dependent - by a guiding mechanism of the rigid axle (dependent suspension). The first solution is frequently used for passenger cars (for both front and rear wheels), while the second solution is mainly used for the rear axles of the larger gauge vehicles (e.g. commercial vehicles) [1-4].

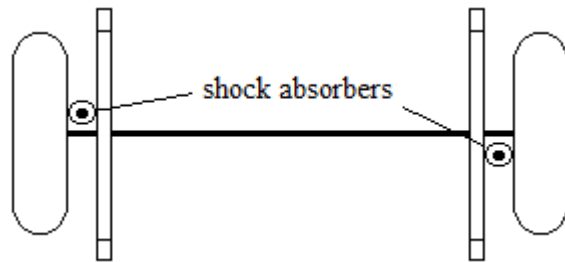
In the classic suspension solution of the rear axle with leaf springs, the spring ensures (besides the main role of elastic element) the axle guiding relative to chassis. A solution to improve the vehicle comfort in the case of suspension with leaf springs consists of the use of soft springs (with a small number of leaves/foils, one or two usually). In the case of these soft spring suspensions, the twisting of the leaf springs into an 'S' shape occurs during hard acceleration or braking, with negative effects on the vehicle dynamics. The 'S'-the twisting phenomenon is produced/determined by the longitudinal contact forces between wheels and road, which causes the axle to twist around its own axis, thus resulting in high bending stress of the leaf spring in the recessed area, and so its deformation into an 'S' shape (Figure 1).

A possible, and also used/implemented, the solution to compensate for the 'S'-twisting consists of the asymmetrical arrangement of the shock absorbers (dampers) relative to the axle longitudinal plane (Figure 2). A semi-constructive variant of such a suspension system is presented in Figure 3. However, this solution is not very effective (efficient) when the wheel contact forces are variable in size and direction.

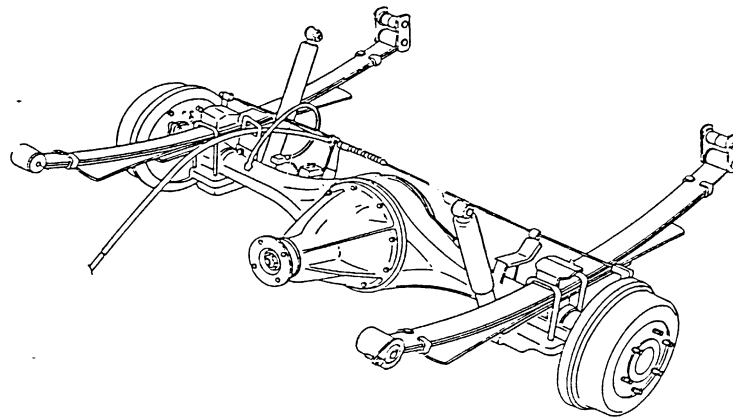




**Figure 1.** The 'S'-twisting of the leaf spring.

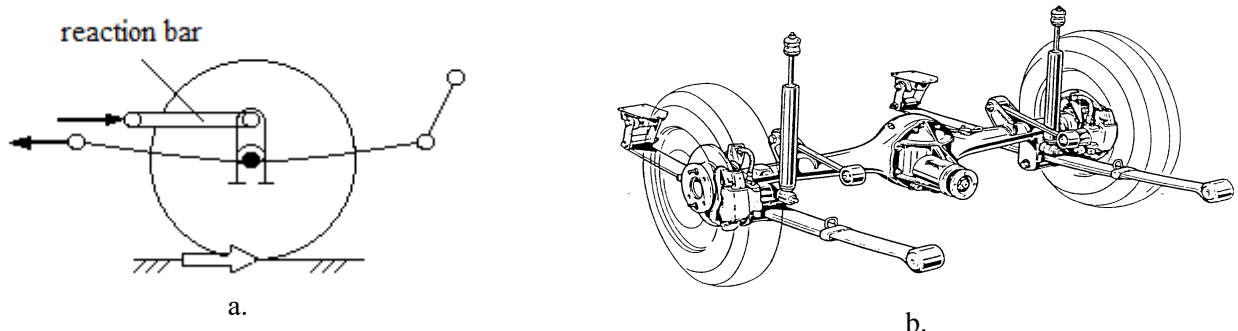


**Figure 2.** Suspension system with shock absorbers arranged asymmetrically.



**Figure 3.** Semi-constructive solution with shock absorbers arranged asymmetrically.

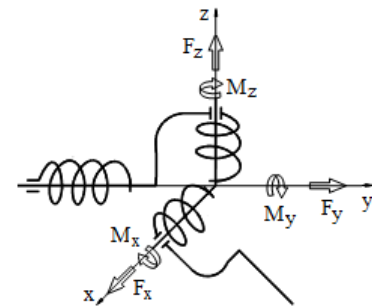
The best solution for minimizing/avoiding the 'S'-twisting of the leaf springs consists in equipping the vehicle suspension with two longitudinal reaction bars (also called traction or slapper bars), as shown in Figure 4.a, with a corresponding semi-constructive model presented in Figure 4.b. The reaction bars can be disposed (arranged) in upper or lower plan in relation to the axle, and they are hinged to axle and chassis by bushings (also called flexiblocks). These compliant joints of rubber have 6 elastic restricted degrees of mobility (DOM), in other words they generate elastic reaction forces and torques on all axes [5], as shown in the theoretical model from Figure 5.



**Figure 4.** The rear axle suspension system with leaf springs and reaction bars.

The role of reaction bars is to take over the longitudinal contact forces from the wheels so that the springs are only loaded with traction and compression, without being subjected to bending. The so obtained suspension system combines the features of the multi-link axle guiding mechanisms with coil springs (as they are defined and systematized in [1]) and the classical suspension with hard leaf springs.

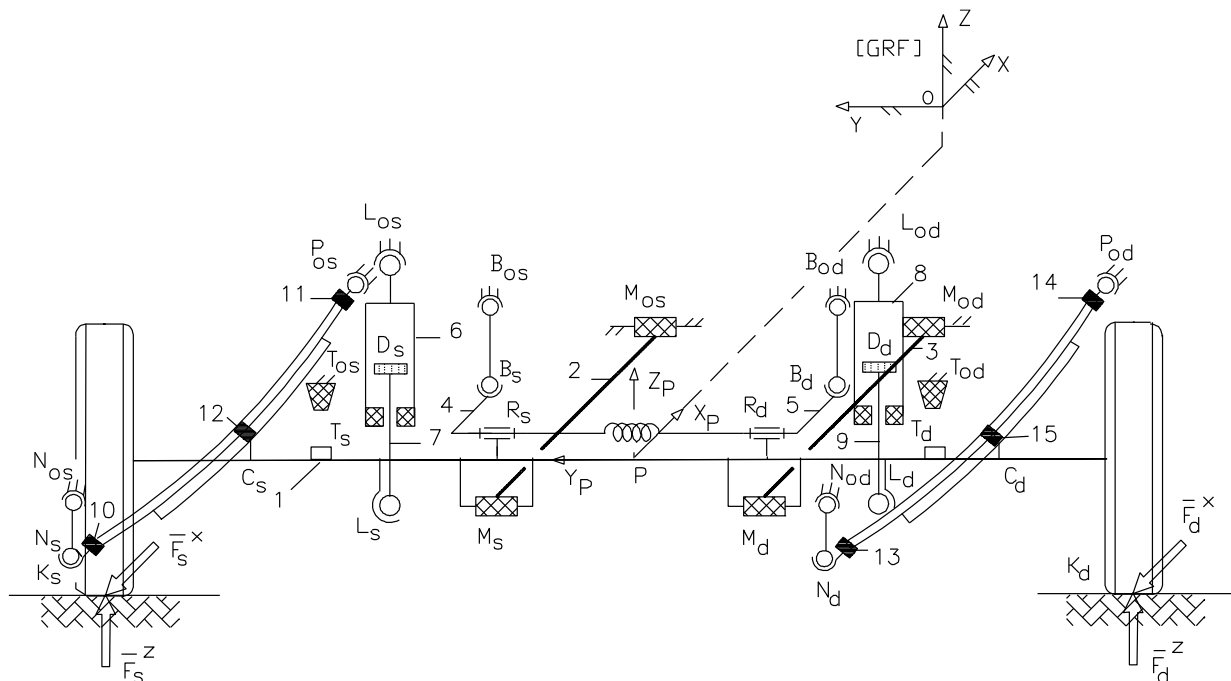
In this paper, the effectiveness of the vehicle suspension with leaf springs and reaction bars is verified through a comparative analysis with the corresponding classical suspension with leaf springs. In this regard, the static models of the two suspension systems have been conceived and analyzed through the use of the facilities achieved by the virtual prototyping package ADAMS, which is currently developed and maintained by MSC Software, a global leader in CAE software development and services. The benefits of using such advanced software solutions in the design process of mechanical & mechatronic systems are reflected in more competitive products, for various types of applications [6-9].



**Figure 5.** The modelling of the bushing.

## 2. Defining the static model

It is well-known that the statics is an out-of-time analysis, which is concerned with the analysis of loads acting on systems that do not experience an acceleration. There are the following input parameters for the static analysis: the assembled configuration of the mechanical system (including the bodies and the connections between bodies), the loads through forces and/or torques (excepting the forces that depend on velocity and acceleration, such as damping and inertia forces/torques). The output of the static analysis is represented by the equilibrium/balance configuration (position), when the resultant of all the acting and reacting forces/torques is null [10, 11]. For this work, the static equilibrium configuration of the suspension system will be reported by the twisting angle of the rear axle, corresponding to the rotational movement of the axle around its own axis.



**Figure 6.** The multi-body model of the axle suspension system with leaf springs and reaction bars.

In this regard, the multi-body model of the suspension with leaf springs and reaction bars is presented in Figure 6. The spatial positioning of the axle coordinate system  $PX_P Y_P Z_P$  with respect to the global coordinate system  $OXYZ$  determines the relative movement in the suspension system. The global frame is attached to chassis (car body), which is considered to be fixed in the static analysis. When the vehicle, therefore the suspension system, is at rest (this being the initial reference position), the local axes  $X_P$ ,  $Y_P$  and  $Z_P$  are arranged parallel to the corresponding ones from the global frame. The suspension system

is externally loaded by the vertical ( $F^Z$ ) and longitudinal ( $F^X$ ) contact forces between wheels and road (ground), corresponding to the traction-braking regime.

Because the leaf spring assures, in addition to the main role of elastic suspension element, the guiding function of the axle (denoted by '1' in Figure 6) relative to chassis, three parts were used to materialize a leaf spring in the multi-body model conceived in ADAMS. Thus, the leaf spring was modeled by two point masses placed at the ends of the spring ('10-11' for the left spring, and '13-14' for the right spring), which are connected to the car body (at the front end) and respectively to the spring ring (at the rear end) by spherical joints, while the third part of the spring ('12', and respectively '15'), which concentrates its mass, it is located in the middle area, being rigidly connected to the axle (in fact, this fixed joint materializes the spring flange/clamp). The three bodies that model a leaf spring are interconnected by elastic elements with uniform cross-section ("massless beam" in ADAMS). The beam (whose modelling is based on the material properties of the leaf spring) transmits forces according to the Timoshenko beam theory [12].

The spring ring, which has a reduced mass compared to the other bodies from the suspension system, was modeled as a constant distance constraint (spherical - spherical composed restriction, namely  $N_{0s}$ - $N_s$  and  $N_{0d}$ - $N_d$ , by case) between the adjacent bodies (the car body and the spring rear part '10/13'). The same type of constraint was used for the modeling of the anti-roll bar tierods ( $B_{0s}$ - $B_s$  and  $B_{0d}$ - $B_d$ ), the anti-roll bar itself being modeled by two parts (denoted by '4' and '5' in Figure 6) between which a torsion spring is disposed.

The shock absorbers were modeled not only as internal force generating elements (which, however, for the static analysis have no influence, because the damping forces depend on velocity, so time), but also as kinematic elements, through two bodies/parts per damper, materializing its cylinder and piston ('6-7' for the left damper, and '8-9' for the right damper), which are connected to chassis and axle by spherical joints, and coupled together by a cylindrical joint.

In these terms, the static model of the axle suspension system with leaf springs and reaction bars (denoted by '2' and '3' in Figure 6) is defined by the following:

- generalized coordinates for 15 mobile bodies:  $15 \times 6 = 90$ ;
- geometrical constraints generated by the mechanical connections:
  - spherical - spherical composed restrictions ( $B_{0s}$  -  $B_s$ ,  $B_{0d}$  -  $B_d$ ,  $N_{0s}$  -  $N_s$ ,  $N_{0d}$  -  $N_d$ ):  $4 \times 1 = 4$ ,
  - revolute joints ( $R_s$ ,  $R_d$ ):  $2 \times 5 = 10$ ,
  - spherical joints ( $L_{0s}$ ,  $L_{0d}$ ,  $L_s$ ,  $L_d$ ,  $P_{0s}$ ,  $P_{0d}$ ):  $6 \times 3 = 18$ ,
  - cylindrical joints ( $D_s$ ,  $D_d$ ):  $2 \times 4 = 8$ ,
  - fixed joints ( $C_s$ ,  $C_d$ ):  $2 \times 6 = 12$ .

The degree of freedom (DOF) of the suspension mechanism, which expresses the number of uncontrolled (independent) movements, which take place under forces action, can be computed by using the Gruebler's count,  $DOF = 6n - \sum r$ , where  $n$  - the number of mobile bodies, and  $\sum r$  - the sum of geometric constraints, resulting:  $DOF = 90 - 52 = 38$ . In a similar way, for the classical suspension system with leaf springs (without reaction bars, so with 13 mobile bodies), there is obtained:  $DOF = 78 - 52 = 26$ . It should be mentioned that in the classical suspension there is the same number of geometric constraints as for the suspension with reaction bars, although the reaction bars are missing (so are their connections) because these connections are made by bushings, which - as mentioned - do not introduce constraints, but they are force generating elements (as shown in Figure 5). Therefore, the difference in number of degrees of freedom between the two suspension systems is only given by the number of generalized coordinates of the reaction bars.

### 3. Results and conclusions

The above presented suspension models (with and without reactions bars) were modeled in ADAMS/View (which is the general pre-processing interface of the MSC.ADAMS suite of software), the static analysis being performed by using ADAMS/Solver (a powerful numerical analysis application that automatically formulates and solves the motion equations).

The comparative analysis was performed by considering the following values for the contact forces on wheels: normal (vertical) reaction forces:  $F_{s,d}^Z = 292$  daN, longitudinal reaction forces:  $F_{s,d}^X \in [-400, 400]$  daN.

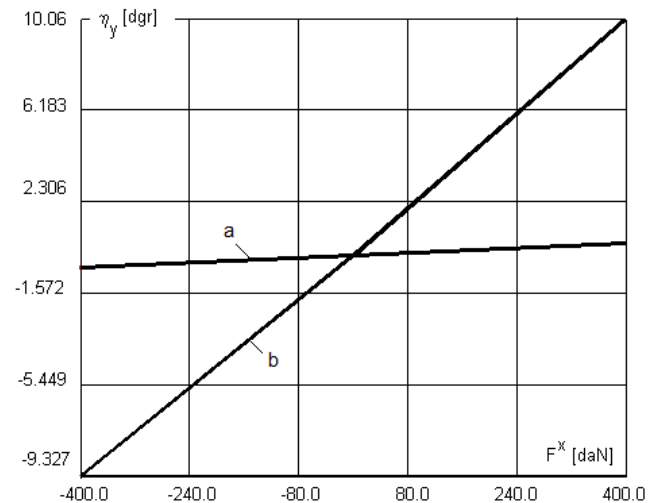
As mentioned, the parameter of interest is the twisting angle of the axle (denoted  $\eta_y$  in Figure 7), which actually determines the 'S'-twisting of the leaf springs. In these terms, in accordance with the diagrams shown in Figure 7, in case of the suspension system with reaction bars (curve 'a') the 'S'-twisting of the leaf springs is very small compared with that corresponding to the classical suspension system (curve 'b'). The slight variation of the axle twisting angle that occurs in the case of the reaction bar based

suspension is due to the elasticity/deformability of the bushings by which the bars are connected to the adjacent elements (mainly those from the axle).

In conclusion, the use of the reaction bars makes it possible to use soft leaf springs in the axle suspension system, with the purpose to improve the comfort performance of the vehicle, but without affecting its dynamic behavior.

## References

- [1] Alexandru C 2009 The kinematic optimization of the multi-link suspension mechanism used for rear axle of the motor vehicle *Proceedings of the Romanian Academy - Series A* **10**(3) pp 244-253
- [2] Alexandru P, Macaveiu D and Alexandru C 2012 Design and simulation of a steering gearbox with variable transmission ratio *Proceedings of the Institution of Mechanical Engineers, Part C: Journal of Mechanical Engineering Science* **226** pp 2538-2548
- [3] Knapczyk J and Maniowski M 2006 Elastokinematic modeling and study of five-rod suspension with subframe *Mechanism and Machine Theory* **41**(9) pp 1031-1047
- [4] Knapczyk J and Maniowski M 2010 Optimization of 5-rod car suspension for elastokinematic and dynamic characteristics *The Archive of Mechanical Engineering* **52**(2) pp 133-147
- [5] Alexandru C 2019 Method for the quasi-static analysis of beam axle suspension systems used for road vehicles *Proceedings of the Institution of Mechanical Engineers, Part D: Journal of Automobile Engineering* **233**(7) pp 1818-1833
- [6] Berceanu C and Tarniță D 2010 Aspects regarding the fabrication process of a new fully sensorized artificial hand *Proceedings of the International Conference ModTech* pp 123-126
- [7] Geonea ID, Alexandru C, Margine A and Ungureanu A 2013 Design and simulation of a single DOF human-like leg mechanism *Applied Mechanics and Materials* **332** pp 491-496
- [8] Ioniță M and Alexandru C 2012 Dynamic optimization of the tracking system for a pseudo-azimuthal photovoltaic platform *Journal of Renewable and Sustainable Energy* **4** pp 053117
- [9] Tarniță D, Catană M and Tarniță DN 2016 Design and simulation of an orthotic device for patients with osteoarthritis *Mechanisms and Machine Science* **38** pp 61-77
- [10] Alexandru C 2016 Analytical method for determining the static equilibrium position of the rear axles guiding mechanisms of the motor vehicles *Applied Mechanics and Materials* **841** pp 59-64
- [11] Alexandru C 2018 Method for the kinetostatic analysis of the road vehicles axle suspensions *Mechanisms and Machine Science* **57** pp 57-65
- [12] Timoshenko SP, 1921 On the correction factor for shear of the differential equation for transverse vibrations of bars of uniform cross-section *Philosophical Magazine* pp 744



**Figure 7.** The twisting angle of the rear axle.