



TECHNICAL UNIVERSITY OF CLUJ-NAPOCA

ACTA TECHNICA NAPOCENSIS

Series: Applied Mathematics, Mechanics, and Engineering
Vol. 61, Issue 3, Month, 2018

POWER GENERATION AND STORAGE SYSTEM ADAPTED TO A MEDICAL BICYCLE

Corneliu DRUGĂ

Abstract: The paper presents the design and construction of a power generation and storage system adapted to a medical bicycle (model 70 years), located in the Medical Engineering Laboratory of Transylvania University. Mostly the system consists of a car alternator (synchronous generator), voltage inverter, car storage battery and a digital multimeter. The rotation movement from the bicycle to the alternator is transmitted via a rubber trapezoid strap. The voltage inverter converts the approximately 14.2 V DC (from the alternator output) into alternating current 220V (at the inverter output). Although the system has a simple construction and a low cost price it has a very good efficiency being very useful in the Laboratory of Medical Engineering.

Key words: bicycle, inverter, synchronous generator, storage battery.

1. INTRODUCTION

At present, there are a variety of bicycle models for fitness or medical venues on the market. However, these bikes are divided into three main categories: mechanical, magnetic or elliptical, each with specific advantages and disadvantages. The purchase price differs from one category to another depending on the technical specifications and the facilities offered to the users. It is recommended that when choosing a medical bike, consider the following features:

- Bicycle size dimensions - it is recommended that when purchasing a bicycle we have information about its dimensions in working order.
- Adjusting pedaling resistance - even if at first the bicycle is used with a pedaling resistance as small as possible, it is time to change this resistance to a higher level.
- Display - It is recommended that a fitness bike have a display showing the elapsed time, running speed, distance traveled, calories lost, and heart rate.
- Adjusting the components - saddle (magnetic and mechanical), handlebars,

pedals (especially elliptical ones), it's good to have the adjustable components to adjust to the needs of each user (anthropometric dimensions).

- Power generation and storage system - to reduce electricity consumption in a fitness room or home, one can opt for such a system. It is a suitable power supply and for isolated homes that are not connected to the public power supply network.

2. DESCRIPTION OF THE USED BICYCLE

In sports medicine and in functional recovery rooms, in order to test the effort of the subjects, it is necessary for them to make a dosing effort. The ergometric (medical) bicycle provides, alongside other biomedical devices, the submission by the subject of an effort that can be mechanical power metering, or through torque at the shaft at a certain brake train speed.

The effort test ensures the objectivity of the various forms of insufficient functional mechanisms, insufficient which sometimes do not occur at rest. Especially the functional

exploration a cardiovascular system, respiratory system and basal metabolism.

In athletes, the stress tests highlight the state of the functional mechanisms due to the way in which the specific mode of use of the biochemical resources that underlie the energy generating mechanism during physical effort, the state of the functional mechanisms.

The bicycle model used in this project was produced in the German Democratic Republic (RDG) in the early 1970s. The bike is in the state of operation of the Medical Engineering Laboratory of the Faculty of Product and Environment Design (Transylvania Univ. of Brasov). A schematic description of the bicycle used in this project is shown in Figure 1.a and the electric circuit of the bicycle is shown in Figure 1.b.

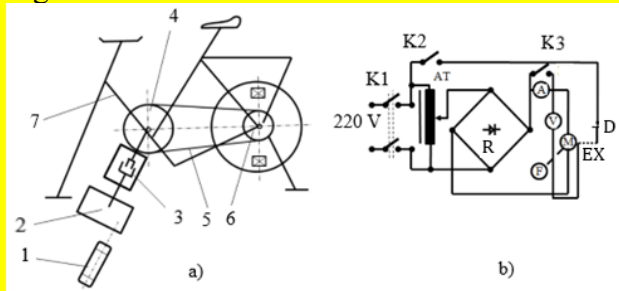

Fig.1. a) The main components of the bicycle: 1- Drive Motor, 2- Rectifier, 3- Way Coupling, 4- Wheel Drive, 5- Gal chain, 6- Brake and sprocket, 7- Frame; **b)** The electric circuit: AT- autotransformer, R-rectifier, M-rotor of the DC drive motor, EX – excitation winding of the motor, D-rectifier diode, V-voltmeter, A-ammeter, K-switch;

Mainly, the electric circuit of this bicycle consists of an autotransformer (from 220V to 36V), a rectifier (consisting of four rectifier diodes), a DC motor, an excitation winding of the motor, an electrodynamic braking system, three switches, a voltmeter and an analogue ammeter to measure the electrical voltage and the currents flowing through the electric circuit (Figure 1.a). The electrodynamic brake of the ergometric bicycle consists of a copper conductor disc, fixed to the braking system shaft by means of steel washers- Figure 2. The brake disk is trained the Gal chain by means of toothed wheels and a one way ball coupling. The excitement electromagnets of the brake are placed on circumference, ensure that their magnetic circuit intersects the brake disc- Figure 2. The DC electromagnets generate an induction

magnetic field (\vec{B}) between the iron, which determines due to the speed (\vec{v} - peripheral disk speed) - an electric field of intensity:

$$\vec{E} = \vec{v} \times \vec{B} \quad (1)$$

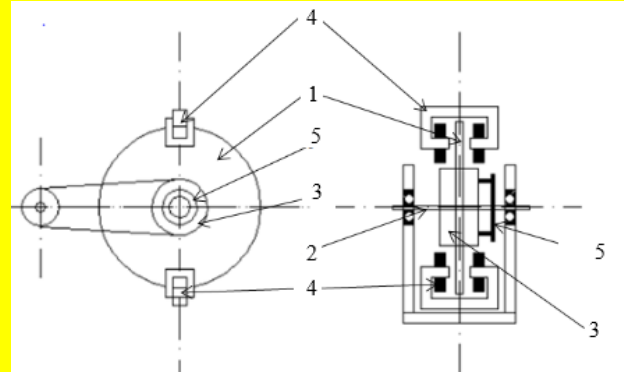

Fig.2.The electrodynamic brake: 1-Brake disc, 2- Brake axle, 3- Washer for fixing the brake disc, 4- Excitation electromagnets of the brake, 5- Drive Gear.[1].

This field determines, in the massive conductor, the occurrence of eddy currents their interaction with the magnetic induction field will give rise to tangential and applied forces eccentric on disk. These forces provide the torque of the ergometric bicycle. The amplitude of the braking torque in this type of bicycle can be varied by varying the supply voltage of the electromagnets disposed on the circumference of the copper disc.

3. SYSTEM DESCRIPTION

Under this system, for the production of electricity, is used a car alternator (Bosch brand), an auto battery of 12V/55A (Rombat brand) for storing electricity, and a sine-wave inverter (Chaomin brand of 800W) for transforming the direct current (14.2V) in alternating current (220V) is used. A digital multimeter AX-18B with USB interface was used to monitor the parameters of the electrical circuit. The car alternator (synchronous generator) is trained by a bicycle flywheel trapezoid, which in turn is trained, via a Gal chain, by the sprocket on the shaft to which the pedals are mounted.

Transmitting the rotation movement from the pinion-pedal system to the flywheel is via a Gal chain, and from the flywheel to the car alternator via a trapezoidal belt.

3.1 Strap transmission

Load transmission is achieved by means of friction which arises between the contact surfaces of the belt and the belt pulleys (in the case of sliding transmissions) or through direct contact between the belt teeth and the wheel (in the case of non-slip transmissions). A belt drive consists of the driving and driven wheels a trapezoidal belt, tightening system and protection guards -Figure 3. Required force of pressing of the strap on the belt pulleys is carried out during assembly by stretching (elastic deformation) belt [2], [3].

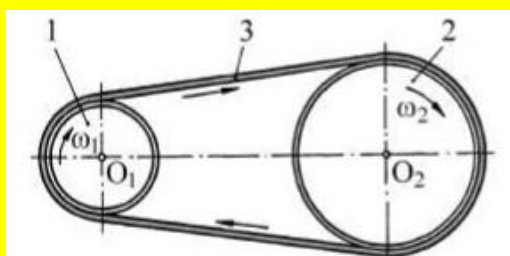

Fig.3. Belt transmission: 1-driving wheel, 2-driven wheel, 3- trapezoidal belt (V-belt);

V-belts are standardized, depending on the size of the section, in two types: classic trapezoidal belts and narrow v-belts. On these belts, the flank in the free state is rectilinear. The belt pulleys for classic and narrow trapezoidal belt transmissions have standardized channel sizes, with the minimum and maximum wheel diameters being limited depending on the type of strap used. The materials used to make the belt pulleys are cast iron, steel, light metal alloys and some plastics.

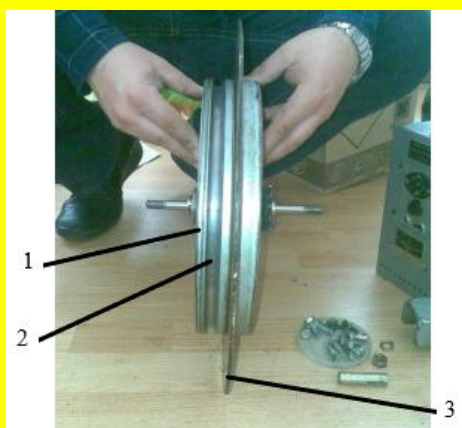

Fig.4. Belt canal: 1- cast iron wheel, 2- belt canal, 3- copper disc;

In the case of this project, the trapezoidal belt groove was made on the flywheel (made of gray cast iron by casting) using a CNC machine tool- Figure 4.

3.2 Car alternator (synchronous generator)

The car alternator is a three phase AC electric motor. It is driven by the thermal motor via the trapezoidal or toothed belt.

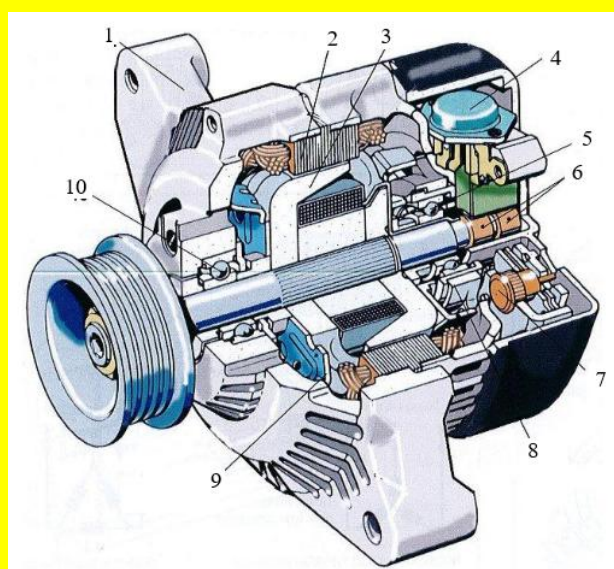

Fig.5. The main components of a car alternator: 1- housing (table), 2-stator, 3- rotor, 4-voltage regulator, 5-bearing, 6- collector rings, 7-diode rectifier bridge, 8-rear fan, 9- previous fan, 10-bearing.

Depending on the electronic systems in a car, the maximum power consumption can reach 1.7 - 2kW. The alternator must be able to produce this energy and additionally charge the battery [4]. The main components of a car alternator are shown in Figure 5.

The stator is made up of metallic wires over which copper conductors are wound, representing the 3-phase alternators (A, B and C). The windings of the three phases of the stator are connected in the star, each phase having a connection wire with the rectifier bridge- Figure 6. The rectifier bridge contains in 6 diodes integrated into an aluminum radiator. For each phase of the alternator, two diodes are used to convert the alternating current to continuous

power (DC)- Figure 6. Of such a diode rectifier bridge is also intended to block the flow of battery current from the battery to alternator, if the alternator voltage drops below the battery voltage - Figure 6. The rectifying bridge is integrated into the rear alternator housing [5].

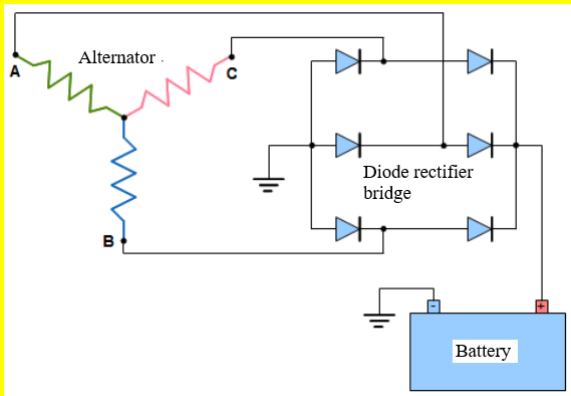

Fig.6. Simplified electric circuit of the car alternator.

The three stator phases produce sinusoidal current. Each phase of the stator is connected between two diodes in the rectifier bridge. One of the two diodes is called positive diode and the other negative diode.

The transformation of the waveform of the current produced by the alternator is shown in Figure 7. In the example of Figure 7, the phases A and B are traversed by electric current; the terminal of phase A is negative and terminal B is positive.

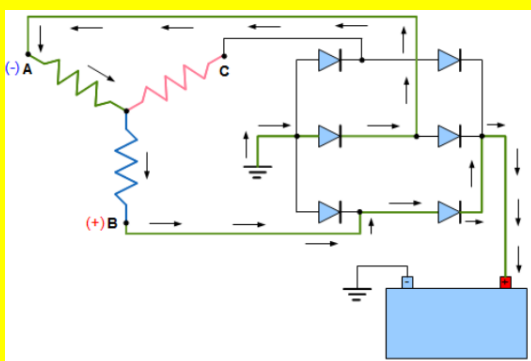

Fig.7. Generating electricity in the alternator stator – example [6].

The two phases are connected in series with the electric current being used to power the battery. After recovery the electric current will always have positive values (Figure 8).

The rectifier bridge will only generate positive electric current. Due to the alternation of the stator phases the current entering the

battery will not be pulsating but will only be formed by the currents of the battery to each phase [4], [5], [6].

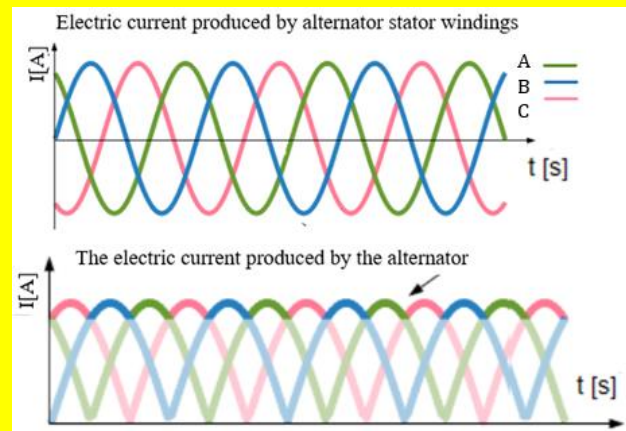

Fig.8. The electric current produced by the car alternator.

The frequency of the current produced by the alternator depends on the rotor speed and the number of poles magnetic:

$$f = p * n / 60 \quad (2)$$

Where: f - alternator current frequency [Hz];
 p - the number of pairs of poles; n - rotor speed [rpm]. The rotor speed is twice as high as the engine speed. So at a speed of idle speed of 1000 rpm for a 6 pole pair (12 poles) alternator, the frequency of the electricity produced will be:

$$f = 6 * 2000 / 60 = 200Hz \quad (3)$$

To prevent the battery from overloading, the voltage generated by the alternator it must be maintained constantly regardless of engine running and operating conditions electricity consumption of the automobile.

3.3 Sine-wave inverter

The auto inverter is a device that converts the direct current (DC) to AC current by ensuring the frequency of 50Hz. The inverter used in this project is one from Chaomin with power of 800W- Figure 9. This inverter converts the voltage of 12V DC (from the car battery) to a voltage of 220V (AC) or in this case from 14.2-14.4V DC from the output of the alternator to a 220V AC supply voltage at the output. Made with the advanced adaptation of chip technology, it has several advantages: it is

smaller, lighter, more silent, and more efficient in transforming energy. Multiple circuits protect the way electrical circuits and equipment in use. In addition, the additional 5V USB charges the 60W-400W output socket and can be used directly to electrical devices that are charging through the USB interface, such as MP3, Digital Cameras and Mobile Phones.



Fig.9. Auto inverter Chaomin (China) 12V/220V with power of 800W.

Technical specifications of the Auto inverter are [7]:

- Output Voltage: 220 VAC +/- 5%;
- Frequency 50 Hz +/- 2 Hz;
- Empty power (without consumer): <0.3 A (at 12 V) ~ 3 W;
- Maximum yield (efficiency) > 90%;
- Continuous (constant) power for 30 minutes: 800 W power output;
- Constant power: 700 watts output power;
- Power tips 1600W (for start-ups);
- Power Beach 10 - 15 V;
- Battery discharge alarm 10.4 - 11 V;
- Automatic disconnect point (battery discharged) to protect the battery: 9.7 - 10.3 V;
- Surge voltage disconnection point at battery terminals: 14.5 - 15.5;
- Protection against overload, low battery, overload, short circuit, high temperature.

3.4 CAD system model

For the design of the entire assembly (ergometric bicycle and power generation and storage system), the CATIA V5 software, available at the Faculty of Product and Environment Licensing, was used.

Steps to design your energy production system electric and ergometric bicycle: 1-Achieving the ergometric bike stand; 2-Alternator, trapezoid belt, bicycle frame and

control box were taken from the GRABCAD.com site and assembled in the CATIA; 3-Assembling the stand with the bicycle support frame; 4-Achieving the support frame for the alternator; 5-Making the electrodynamic brake; 6-Assembling the control box, fastening system and drive system of alternator. The final CAD model of the whole assembly is shown in Figure 10.

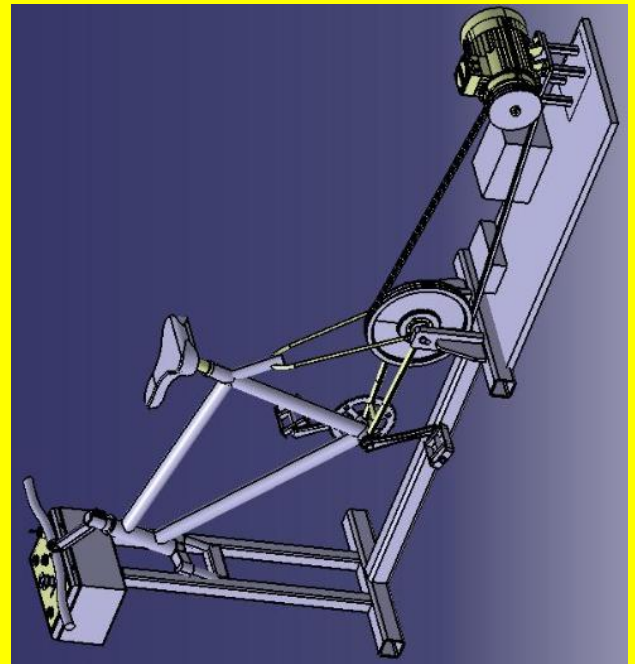

Fig.10. Final CAD model of the whole assembly,

4. RESULTS

The entire assembly (the power generation system and the medical bicycle) was assembled and then tested in the Medical Engineering Laboratory - Figure 11. After commissioning, testing of the system was carried out by powering various inverters (220VAC) and electric appliances and a laptop but not exceeding 800W (Figure 11).



Fig.11. Testing of the system in the Medical Engineering Laboratory

After several test cycles, it has been found that the system has a good yield which recommends it for use in the Medical Engineering Laboratory and beyond.

5. CONCLUSIONS

Although it is a low-cost system, which can also be achieved with components recovered from automobiles, it is efficient both for the production and storage of electricity, but also for exercise in fitness halls or in dwellings that are not connected to the power supply network electricity. Depending on the devices to be powered from this system, the 800W inverter can be replaced with a higher power output up to 3000W. The energy storage battery produced may change with a higher power rating. The system can also be used to light houses in isolated areas where there is no power supply, using incandescent bulbs or LEDs.

6. REFERENCES

[1] Matlac I, Borza P., *Aparatura medicala, Îndrumator de laborator*, Rep. Inst. Politehnic din Braşov, pp.4-7, 1987;

[2] Dimitrache G, Nătescu N, Zamfir V., *Organe de masini: Transmisii prin curele: Transmisii prin lanturi: Îndrumar de proiectare*, Ed. Univ. Transilvania din Braşov, pp.10-14, 1992;

[3] Jula A, Chisu E, Lates M., *Transmisii mecanice*, Ed. Univ. Transilvania din Braşov, pp. 135–1140, 2006;

[4] Mailat A., *Surse de energie electrica pentru vehicule*, Ed. Univ. Transilvania din Braşov, pp.37-45, 2009;

[5] Topa I, Mailat A, Szabo W., *Instalație pentru determinarea parametrilor electrici ai alternatoarelor auto*, Ed. Electrotehnica, Bucuresti, 1979;

[6] Ciobanu A., *Realizarea unui sistem de producere a energiei electrice folosind o bicicletă medicală*, Lucrare de dizertatie, Univ. Transilvania din Braşov, coord. Dr.ing. C. Druga, pp. 20-30, 2014.

[7]https://www.alibaba.com/product-detail/800W-DC12V-24V-toA110V220V_803860287.html

Sistem de producere si inmagazinare a energiei electrice adaptat la o bicicleta medicala

Rezumat: Lucrare prezinta proiectarea si constructia unui sistem de producere si inmagazinare a energie electrice, adaptat la o bicicletă medicală (model anii 70), aflată în Laboratorul de Inginerie Medicala din cadrul Universităţii Transilvania. In mare parte sistemul consta dintr-un: alternator auto, inverter de tensiune, baterie auto si un multimetru digital. Miscarea de rotatie de la bicicleta la alternator se transmite prin intermediul unei curei trapezoidale din cauciuc. Inverterul de tensiune converteste cei aproximativ 14.2 V curent continuu (de la iesirea alternatorului) in 220V curent alternativ (la iesirea inverterului). Sistemul desi are o constructie simpla si un pret de cost scazut are un randament foarte bun fiind foarte util in Laboratorul de Inginerie Medicala.

Corneliu Druga, Lect.dr.eng., Transylvania Univ. Of Braşov, DPMM, druga@unitbv.ro, 0773929395