

PAPER • OPEN ACCESS

## Dynamic simulation of the adaptive sun tracking system used for an electric unmanned ground vehicle

To cite this article: C Alexandru 2019 *IOP Conf. Ser.: Mater. Sci. Eng.* **568** 012019

View the [article online](#) for updates and enhancements.

You may also like

- [Design and Control of Autonomous Rover for Foliage Navigation](#)  
Kin Long Chow and Swee King Phang
- [Research on lie group dynamics modeling and trajectory-tracking optimal control of intelligent ground vehicle](#)  
Te Chen, Zikun Zhang, Xu Xing et al.
- [Research on control method and evaluation system of unmanned ground vehicle group change](#)  
Tianyu Shi, Yunqing Bao, Zhichao Wang et al.



**UNITED THROUGH SCIENCE & TECHNOLOGY**

 **The Electrochemical Society**  
Advancing solid state & electrochemical science & technology

**248th  
ECS Meeting**  
Chicago, IL  
October 12-16, 2025  
*Hilton Chicago*

**Science +  
Technology +  
YOU!**

**Register by  
September 22  
to save \$\$**

**REGISTER NOW**

# Dynamic simulation of the adaptive sun tracking system used for an electric unmanned ground vehicle

**C Alexandru**

Transilvania University of Braşov, Romania

E-mail: calex@unitbv.ro

**Abstract.** In this article, the modeling and simulation of the adaptive sun tracking system used for an electric unmanned ground vehicle is carried out. The power supply of the vehicle is an electric one, supported by a photovoltaic (PV) panel with solar tracker, which is positioned on the upper platform of the vehicle (practically, the tracking system thus defined is one with mobile base). The main feature of the adaptive tracking mechanism consists in its ability to correlate the predefined tracking law (which it is designed as system would be one with fixed base) with the random movement of the vehicle. The mechatronic model contains both mechanical and electronic (control) elements, being conceived and analyzed in virtual prototyping environment by using the MBS software package ADAMS.

## 1. Introduction

The unmanned ground vehicles (UGV) are autonomous robotic systems, without human operator on board, which are frequently used for applications where human presence is not possible or necessary (for example, in agriculture or military applications), for various purposes, such as detecting and/or removing objects, collecting data about the environment, and others [1-3]. These vehicles are usually electrically driven, the energy being stored in batteries fitted to the vehicle. For long-term operation, photovoltaic panels can be attached to the vehicle, to provide supplementary energy or to charge the batteries. Solar tracking mechanisms can improve the conversion system efficiency by maximizing the incident solar radiation on the panel surface [4-8]. The existing solar trackers are predominantly mechatronic systems, which integrates mechanical and control components, whose drive is made by actuators (motors) that are commanded so that to allow a more accurate sun tracking.

The literature reveals many types of solar trackers (more or less complex), in mono-axial and bi-axial configurations (with one or two degrees of mobility). Usually, the mono-axial systems are used to track the sun diurnal movement, while the bi-axial systems are able to assure the both movements in the Earth - Sun system, namely the diurnal and elevation (altitudinal) motions [9-14]. Unlike the most existing tracking systems, whose base (support) is fixed connected to ground, the tracking mechanism proposed in this work has mobile base (namely the platform of the unmanned ground vehicle), making it necessary to adapt (correlate) the predefined tracking law (which it is designed as system would be one with fixed base) with the random movement of the vehicle. The software package ADAMS has been used to model and simulate the adaptive sun tracker behavior. Such a virtual prototyping solution provides important benefits, as pointed out in [15-19]. For this study, only the yaw movement of the vehicle was taken into account, the PV tracking system being approached in the mono-axial version, which is derived from an azimuthally system, the axis of the diurnal motion being vertically oriented, parallel to the axis around which the vehicle yaw occurs (by turning to the left - right).



## 2. Tracking system modeling

The design algorithm (flow-chart) of the sun trackers is based on building and testing the kinematic, inverse dynamic, and direct dynamic models, as presented in [20]. By going through this algorithm, the sun tracking mechanism for this work (which is a mono-axial azimuthally system) has been designed, the virtual model conceived in ADAMS being shown in Figure 1.

The tracking system contains the vertical pillar (1), on which the fixed part of the drive motor (based on worm gear reducer) is mounted, the moving part of the motor (i.e. the rotor) being coupled to the support frame (2) of the PV panel (3). The diurnal movement is carried out by rotating the panel (along with the support on which it is mounted) around the vertical axis - x.

In the classical variant of tracking system with fixed base, the pillar is rigidly connected to ground. The diurnal movement is performed according to a stepping orientation function, developed so as to ensure an optimal number of motion steps, with a minimal energy demand to carry out the sun tracking, what will be found in increasing the PV system efficiency. The application for this article has been conceived considering the summer solstice day, and the Braşov implementation area, which actually determines the orientation path.

The angular domain of the diurnal motion is  $180^\circ$ , in the interval  $\psi^* \in [90^\circ, -90^\circ]$ , with the following actuating timing (in local time): 9.819 ( $\Delta\psi^*=21^\circ$ ), 11.439 ( $\Delta\psi^*=30^\circ$ ), 12.769 ( $\Delta\psi^*=39^\circ$ ), 13.869 ( $\Delta\psi^*=39^\circ$ ), 15.199 ( $\Delta\psi^*=30^\circ$ ), 16.819 ( $\Delta\psi^*=21^\circ$ ), 21.166 ( $\Delta\psi^*=-180^\circ$  - return to the initial position, after sunset). In ADAMS, the motion law has been modeled by a sum of STEP functions, with the following format STEP(time, begin at, initial value, end at, final value), in which the time is the independent parameter, corresponding to the number of motion steps, in respect with the previously presented values, as follows (where  $d$  indicates that the value is in degrees):

$$F = \text{STEP}(\text{time}, 9.82, 0.0d, 9.92, 21.0d) + \text{STEP}(\text{time}, 11.44, 0.0d, 11.54, 30.0d) + \text{STEP}(\text{time}, 12.77, 0.0d, 12.87, 39.0d) + \text{STEP}(\text{time}, 13.87, 0.0d, 13.97, 39.0d) + \text{STEP}(\text{time}, 15.20, 0.0d, 15.30, 30.0d) + \text{STEP}(\text{time}, 16.82, 0.0d, 16.92, 21.0d) + \text{STEP}(\text{time}, 21.17, 0.0d, 21.27, -180d) \quad (1)$$

It should be mentioned that the final value in a STEP function is expressed by reference to the initial one, which is actually the final one from the previous motion (tracking) step. For example, Figure 2 shows the modeling of the first tracking step, which occurs during the time interval 9.82-9.92.

Under these circumstances, the imposed variation diagram of the diurnal (azimuthally) angle of the PV panel is shown in Figure 3.a, with the corresponding angular velocity in Figure 3.b.

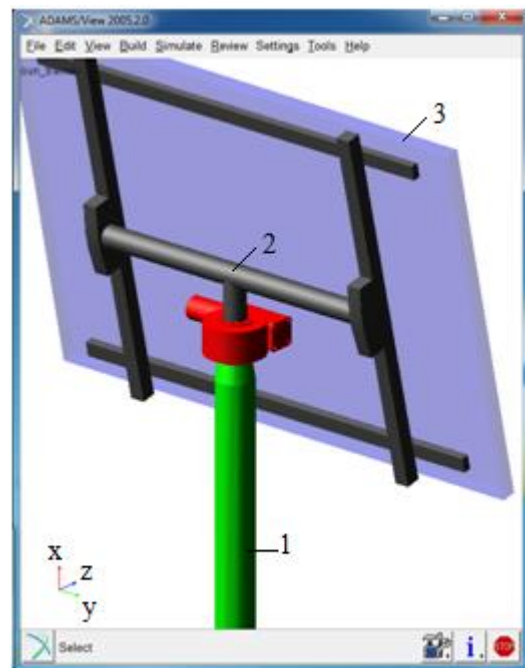

**Figure 1.** The MBS model of the mono-axial azimuthally sun tracker.

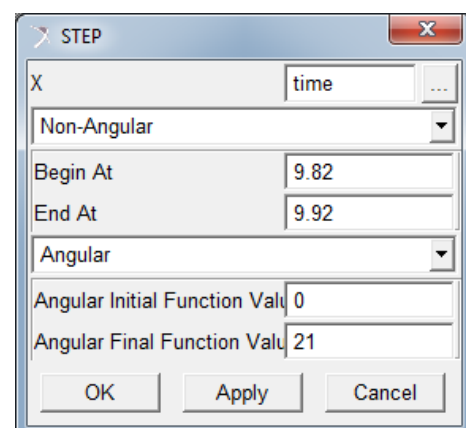

**Figure 2.** The STEP function modeling.

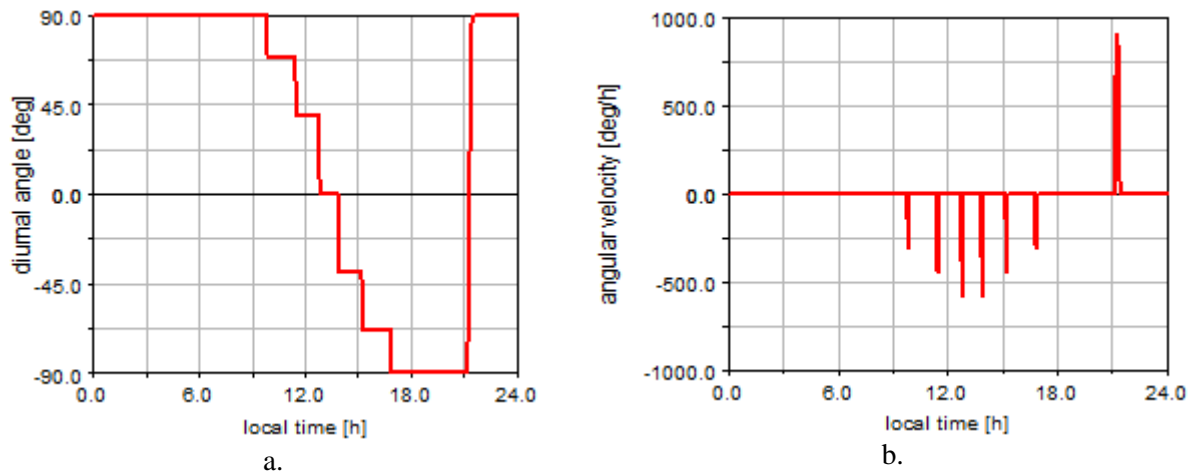

**Figure 3.** The tracking law for the PV system with fixed base.

Afterwards, the so-designed sun tracking mechanism was implemented (mounted) on an unmanned ground vehicle, whose virtual model is the one in Figure 4, the tracking mechanism base (i.e. the vertical pillar) being rigidly connected to the upper platform of the vehicle. For this work, only the yaw movement of the vehicle, which is generated by the vehicle turning to the left or to the right, has been considered. Consequently, the adaptive tracking mechanism must be able to correlate its predefined tracking law (shown in Figure 3), which it is designed as the PV system would be one with fixed base, with the random turning movement of the vehicle, so as to maintain the optimal incidence of solar radiation on the PV panel.

In the virtual model, a sensor is used to measure the yaw angle of the vehicle (in reality, this movement can be measured by using a gyroscope or an accelerometer), the value read by the sensor being then used in the form of a state variable for changing/adapting the tracking law in the control system of the rotary motor for the diurnal motion, as follows:

$$\begin{aligned}
 F = & \text{STEP}(\text{time}, 9.82, 0.0d, 9.92, 21.0d) + \text{STEP}(\text{time}, \\
 & 11.44, 0.0d, 11.54, 30.0d) + \text{STEP}(\text{time}, 12.77, 0.0d, \\
 & 12.87, 39.0d) + \text{STEP}(\text{time}, 13.87, 0.0d, 13.97, 39.0d) \\
 & + \text{STEP}(\text{time}, 15.20, 0.0d, 15.30, 30.0d) + \text{STEP}(\text{time}, \\
 & 16.82, 0.0d, 16.92, 21.0d) + \text{STEP}(\text{time}, 21.17, 0.0d, \\
 & 21.27, -180d) + \text{VARVAL}(\text{VARIABLE}_1)
 \end{aligned} \quad (2)$$

VARVAL being an ADAMS/View predefined function that is used to provide the current value of the variable mentioned in the argument. The variable is defined by using the displacement function YAW, with the following format: YAW(vehicle.MARKER\_101, ground.MARKER\_102). This function returns the first angle of rotation from one coordinate system marker (MARKER\_101, which belongs to the vehicle) to another (MARKER\_102 - belonging to the ground part). In the initial (modeling) position, the two coordinate system markers are coincidental (as location/position, and orientation).

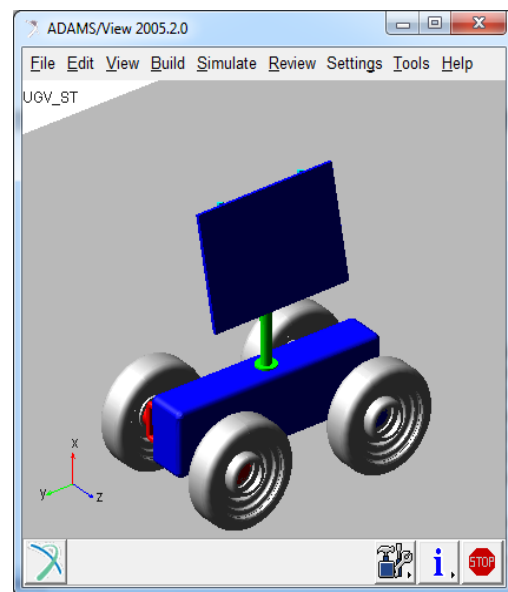

**Figure 4.** The virtual model of the UGV equipped with PV solar tracker.

### 3. Results and conclusions

In the initial position, the vehicle is positioned so that its longitudinal axis ( $y$ ) is directed on the South-North axis, so as to the PV panel is oriented towards the East. If the vehicle would remain stationary in this position throughout the day, then the orientation law of the PV panel would be the one shown in Figure 3. At the beginning of the dynamic simulation, which starts at 8:00 (local hour), the vehicle will move to the South, in a straight line in the first 30 minutes, and then begins to turn left or right (for example, to explore a specific workspace), which generates the change in the yaw angle of the vehicle according to the diagram shown in Figure 5.

The control system of the adaptive sun tracker will correlate of the predefined orientation function (shown in Figure 3) with the random yaw movement of the vehicle, thus making possible the optimal incidence of solar radiation on the PV panel at all times, as if the tracking system were one with a fixed base. The control law thus obtained is that shown in Figure 6.

The effectiveness of the proposed adaptive tracking strategy is also demonstrated by the graphical frames from Figure 7, which are captured at midday (13.206 in local time), at this time the mechanism assuring the best orientation of the PV panel, namely facing South, on  $y$ -axis direction (Figure 7,a), which cannot be assured if the system would be a non-adaptive one (Figure 7,b), meaning that it is not able to correlate the tracking law with the vehicle trajectory.

In a forthcoming work, the adaptability of the PV tracking system will be extended so that to consider other movements of the vehicle, such as the pitch, which occurs when the vehicle goes down-up a slope/ramp or it passes over obstacles.

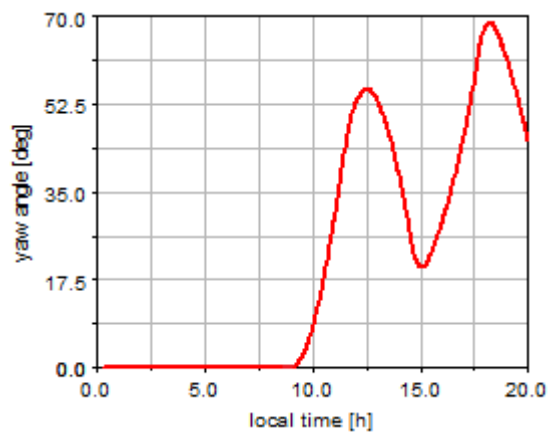

**Figure 5.** The yaw angle of the vehicle.

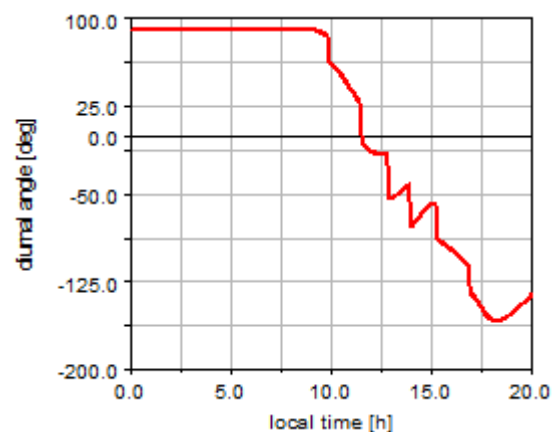

**Figure 6.** The control law for the diurnal motion.

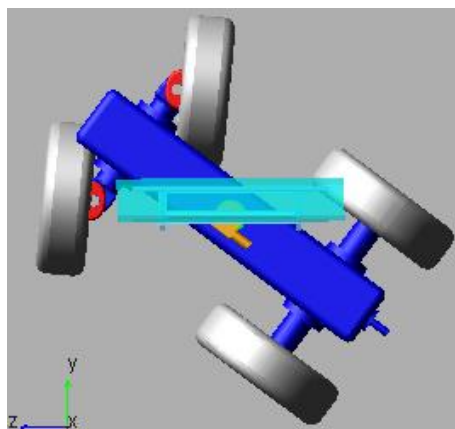

a.

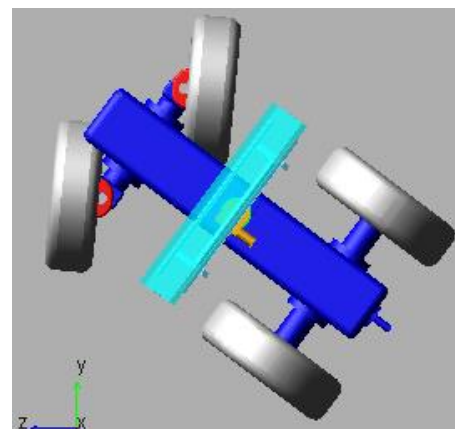

b.

**Figure 7.** Simulation frames for the adaptive (a) and non-adaptive (b) tracking system.

## References

- [1] Durst P, Goodin C, Anderson D and Bethel C 2017 A reference autonomous mobility model *Proceedings of the IEEE Winter Simulation Conference - WSC* pp 4026-4037
- [2] Gage D 1995 A brief history of unmanned ground vehicle (UGV) development efforts *Unmanned Systems Magazine* **13** pp 1-10
- [3] Hassan S, Alam M, Siddiqui N A, Siddiqui A A and Qadri T 2017 Designing and control of autonomous unmanned ground vehicle *Proceedings of the International Conference on Innovations in Electrical Engineering and Computational Technologies - ICIEECT* pp 1-5
- [4] Alexandru C and Comșîț M 2008 The energy balance of the photovoltaic tracking systems using virtual prototyping platform *Proceedings of the 5th IEEE International Conference on the European Electricity Market - EEM* pp 253-258
- [5] Alexandru C 2009 The design and optimization of a photovoltaic tracking mechanism *Proceedings of the 2nd IEEE International Conference on Power Engineering, Energy and Electrical Drives - POWERENG* pp 436-441
- [6] Nsengiyumva W, Chen S G, Hu L and Chen X 2018 Recent advancements and challenges in solar tracking systems (STS): A review *Renewable & Sustainable Energy Reviews* **81** pp 250-279
- [7] Seme S, Stumberger B, Hadziselimovic M 2016 A novel prediction algorithm for solar angles using second derivative of the energy for photovoltaic sun tracking purposes *Solar Energy* **137** pp 201-211
- [8] Sharaf Eldin S A, Abd-Elhady M S and Kandil H A 2016 Feasibility of solar tracking systems for PV panels in hot and cold regions *Renewable Energy* **85** pp 228-233
- [9] Alexandru C and Tatu I N 2013 Optimal design of the solar tracker used for a photovoltaic string *Journal of Renewable and Sustainable Energy* **5** pp 1-16
- [10] Altuzarra O, Macho E, Aginaga J and Petuya V 2015 Design of a solar tracking parallel mechanism with low energy consumption *Proceedings of the Institution of Mechanical Engineers, Part C: Journal of Mechanical Engineering Science* **229** pp 566-579
- [11] Ioniță M and Alexandru C 2012 Dynamic optimization of the tracking system for a pseudo-azimuthal photovoltaic platform *Journal of Renewable and Sustainable Energy* **4** pp 1-15
- [12] Flores-Hernández D A, Palomino-Resendiz S, Lozada-Castillo N and Luviano-Juárez A 2017 Mechatronic design and implementation of a two axes sun tracking photovoltaic system driven by a robotic sensor *Mechatronics* **47** pp 148-159
- [13] Hoffmann F M, Molz R F, Kothe J V, Nara E O B, Pablo L and Tedesco C 2018 Monthly profile analysis based on a two-axis solar tracker proposal for photovoltaic panels *Renewable Energy* **115** pp 750-759
- [14] Vieira R G, Guerra F K, Vale M R and Araujo M M 2016 Comparative performance analysis between static solar panels and single-axis tracking system on a hot climate region near to the equator *Renewable & Sustainable Energy Reviews* **64** pp 672-681
- [15] Alexandru C and Alexandru, P 2010 The virtual prototype of a mechatronic suspension system with active force control *WSEAS Transactions on Systems* **9** pp 927-936
- [16] Alexandru C and Alexandru, P 2011 A comparative analysis between the vehicles' passive and active suspensions *International Journal of Mechanics* **5** pp 371-378
- [17] Alexandru P, Macaveiu D and Alexandru C 2012 Design and simulation of a steering gearbox with variable transmission ratio *Proceedings of the Institution of Mechanical Engineers, Part C: Journal of Mechanical Engineering Science* **226** pp 2538-2548
- [18] Bernard A 2005 Virtual engineering: methods and tools *Journal of Engineering Manufacture* **219** pp 413-421
- [19] Tarniță D, Marghitu D 2013 Analysis of a hand arm system *Robotics and Computer-Integrated Manufacturing* **29**, pp 493-50
- [20] Alexandru C 2019 Multi-body system simulation of the sun trackers used for PV panels *Submitted to IMT'2019*